

Open Parking Structures

Recommendations for the Design, Construction and
Maintenance to Improve Life Cycle Cost and Quality





Preface

Parking structures are a unique blend of bridge and building structure. If a parking structure is designed like a bridge, it is not competitive in the marketplace. If the parking structure is designed like a typical building, the structure will deteriorate over time. The challenge of designing a parking structure is to develop a blend of bridge design and building design to create the optimum combination of function, economy, and durability. [1]

Copyright © 1986

All Rights Reserved

Reproduction or translation of any
part of this work without permission
of the copyright owner is unlawful.



Introduction

The evolution of free-standing, clear span, open parking structures has occurred over a relatively short period of time. Acceptance of the parking structure as an effective economic and social solution did not occur until the mid 1950's. Since then, many shortcomings have been evident in the form of deterioration, costly repairs, and even collapse.

Free-standing parking garages have traditionally been designed as buildings, using the same structural systems which have proven effective for building construction. However, the main problem with parking garage design in the past has been the lack of attention to the unique environmental conditions which the garage must endure. Unlike an enclosed and temperature-controlled building, the parking garage is fully exposed to the outside environment. The structure experiences a full range of temperature and humidity fluctuations as well as direct wind, rain, ice, snow, and freeze/thaw cycles. In addition, man-made environmental conditions, such as the application of salt for deicing, must also be endured in colder regions.

Temperature differentials can fluctuate by as much as 45 degrees in a single day and 100 degrees between July and January, which causes severe movements in the exposed structure due to expansion and contraction. If the structure is not designed or built properly to accommodate this thermal movement, as well as traffic-generated movement, then cracking will occur. Cracking is followed by corrosion of reinforcing, spalling, and other structural damage due to moisture intrusion. Moisture is introduced by direct rain, atmospheric humidity, leaky drain lines, and water dripping off vehicles on rainy days.

The evolution of structural systems for today's parking garages has been influenced by functional requirements of span and column spacing and by cost. Economical structural systems that can span great distances have become commonplace. The desire for column-free space has dictated a requirement for 55 to 62 foot clear spans for a typical parking bay, which rules out conventionally reinforced cast-in-place concrete schemes such as flat slabs and pan joists. These have been used for garage construction in the past but cannot adapt to the long spans required for column-free aisles. Parking consultants recognize that column-free garages allow easier parking and maneuvering, accommodate two-way traffic, are more efficient, and are flexible for restriping as vehicle sizes change.

Another major consideration in open parking structure design is the desire for maintenance-free service. Maintenance costs on a poorly designed garage can be severe. A garage system that is the most economical to construct may have such high maintenance costs that, over a 10 year period, it becomes the most expensive system. Parking garage owners and managers do not want to become burdened with maintenance that is beyond routine. Maintenance can be expensive, time-consuming, unsightly, and result in temporary shutdown of parking spaces, driving aisles, and even the garage itself. Therefore, a comprehensive cost study of a long-span open parking garage design must include life-cycle maintenance costs, in addition to initial construction cost. The designer who spends sufficient time on details and knows how to build in maintenance-free features will create a structure that is much easier and less expensive to maintain.

There are three structural material families that can accomplish the long spans required:

1. **Precast columns, beams, and double tees with or without topping.**
 2. **Cast-in-place, post-tensioned beam and slab (or joists).**
 3. **Structural steel beams, girders, and columns with composite slabs.**
-



Introduction

In addition, there are hybrid schemes which utilize parts of each material family, such as steel columns and beams supporting precast planks, or cast-in-place columns with precast beams and double tees.

The precast garage, post-tensioned cast-in-place garage, and the structural steel garage have proven to be the three most effective modern solutions to garage construction.

This report discusses the advantages, disadvantages, and key specification items of each of six different structural systems. Each system has its own set of problems which must be addressed and effectively resolved on each particular project to ensure successful performance. This report includes an analysis of these problems and proposed solutions for them, as well as recommended construction details for each system.

A tabulation of material quantities is provided in each section for use in developing comparative cost estimates. Actual costs will vary from job to job, based on the building geometry and site conditions. Each particular project must be evaluated as to the relative merits of each different structural solution for the particular site, building configuration, environment, and construction market. A cost analysis of the structural system is especially important because the structural cost is 70% to 75% of the total garage cost. Quantities for anticipated life-cycle maintenance costs are presented for each system to aid in the evaluation. Relative costs, with functional advantages and disadvantages, should be compared during the design development phase of the project in order to select the right structural system. Then the selected system should be refined during the Construction Document phase. Rounding out the report are chapters devoted to special design considerations and quality control, followed by some general conclusions.

We hope that this document will aid in the selection of a structural system and will help to educate the design team, contractor, and owner about concerns which must be addressed in order to construct and maintain a successful parking structure.

Table of Contents

Introduction	
Datum's Parking Garage Experience	Chapter 1
Structural Systems	Chapter 2
Topped Precast Concrete	Chapter 3
Untopped Precast Concrete	Chapter 4
Post-Tensioned Beam and Slab	Chapter 5
Post-Tensioned Pan Joists	Chapter 6
Precast Frame with Formed Slab	Chapter 7
Steel Frame with Formed Slab	Chapter 8
Undesirable Systems for Clear Span Open Garages	Chapter 9
Special Design Considerations	Chapter 10
Quality Control	Chapter 11
Conclusion	Chapter 12
References	Chapter 13

Revision Dates: March 1987
December 1987
April 1989
May 1992
April 1994
May 1999
October 2001
September 2005
February 2011
October 2011

Datum Engineers, Inc., assumes no liability for the use by others of material contained in this book. No warranty is expressed or implied.





Parking Garage Experience 1

AWARD OF MERIT: PARKING STRUCTURES



NORTH PARK CENTER PARKING STRUCTURES



NORTH PARK CENTER - GARAGES G1 & G2

Location: Dallas, Texas

Submitted by: Datum Engineers, Inc.

Owner: NorthPark Management Company

Architect: Omniplan, Inc.

Engineer: Datum Engineers, Inc.

Contractor: The Whiting-Turner Contracting Company

P/T Supplier: Ready Cable

Other Contributors: Capform, Forming & Rebar Placement; Lofland, Mild Reinforcement

OVERVIEW:

In late 2003, NorthPark Center began a shopping mall expansion project which included two new parking garages on the north side completed in 2005. Garage G1 has five levels, 598,000 sq ft, and 1671 parking spaces. It cost a total of \$13,420,000, with \$504,000 in post-tensioning. Garage G2 has six levels, 850,700 sq ft, and 2235 parking spaces. Its cost was \$18,429,000, including \$755,000 in post-tensioning. A critical goal met was for the structures to be open for that year's holiday shopping season. The first garage took 31 weeks, and the second garage took 39 weeks to construct.

At the beginning of the project, the contractor priced a cast-in-place post-tensioned garage and a precast parking garage. The precast option was slightly less expensive based only on initial construction, but would have been more expensive over time because the life cycle costs benefit the post-tensioned option. In addition, the upturned spandrel beam with offset perimeter columns would not easily work with precast construction. Both garages have very long plan dimensions and upturned perimeter beams along the garage perimeter. These beams provide structural support for the slab, resist car impact forces, and provide backup for the brick veneer. In addition, they allow more sunlight and air into the parking garage.

The jury was impressed with the way a wide range of spans were accommodated using post-tensioning. They noticed the efficient use of upturned beams at the edges. Also impressive was the very quick construction time. The jury found that these garages demonstrate that post-tensioning can be less expensive than precast in a project of this nature.

The 50 Most Significant Precast Concrete Projects

Precast/Prestressed Concrete Institute's members select the 50 projects that have most impacted the design and construction industries



Reprinted from PCI's ASCENT® magazine Winter 2004

An enormous number of projects have been created by imaginative and pioneering designers who looked to precast concrete to meet the challenges they faced. Innovative projects as diverse as stadiums, bridges, parking structures, offices, schools, housing and industrial buildings have been produced. These designers have not only expanded the ways in which precast concrete was used, but have also devised new techniques embraced by the entire design community.

To celebrate the 50th anniversary of the Precast/Prestressed Concrete Institute, the organization has selected the 50 most significant projects using precast concrete components. The selections came from nearly 400 candidates nominated over a number of years by precast concrete producers, engineering firms and designers. That list was cut to approximately six dozen.

The final selection by a panel of designers, engineers and others in the building community proved difficult due to the substantial number of projects that truly offer breathtaking design and innovation.

Presented on these pages are the best of the best, the 50 most significant projects in North America to feature precast concrete components, listed in chronological order by completion date. They represent the tip of the iceberg in terms of creativity, effectiveness and aesthetically pleasing designs created in the past 50-plus years.

Special thanks to Norman L. Scott of The Consulting Engineers Group and his committee for their work in selecting the 50 projects presented in this special report.



1974

Baylor Hospital Parking Structure DALLAS

A new concept for constructing precast concrete parking structures was conceived for this project. Precast concrete walls ("stack walls") were used for the first time, incorporating haunches to support the sloping ramp floor on one side and the horizontal floor on the opposite side. After this project, many parking structures were designed using this notion, with either solid walls or with punched openings commonly called "lite walls."



EXCELLENCE IN ARCHITECTURAL AND ENGINEERING DESIGN

Parking Structure
Baylor Medical Center
Dallas, Texas



Owner: Baylor University Medical Center
Architect: Harwood K. Smith & Partners, Inc.
Structural Engineer: Datum Engineers, Inc.
General Contractor: Hayman-Andres

The Baylor University Medical Center six-level parking facility, completed in September 1974 at a cost of \$1.8 million, was one of 19 prestressed precast structures recognized for "excellence in architectural and engineering design" by the Precast/Prestressed Concrete Institute.

The only parking structure so honored in 1974, it was cited for achievement in "esthetic expression, function and economy."

Its visual appeal stems largely from the exterior spandrel beams which support the floor and also serves as the guard rail. These beams are slabs seven inches thick with slots on four foot centers to accommodate the precast tees which comprise the floor. A total of 585 60-foot-long double tees were required. All prestressed and pre-cast components were sandblasted to create a natural finish requiring virtually no maintenance.

The interior wall system features full height (44 feet) precast walls which support both level floor and sloping ramp, and eliminate the need for obtrusive interior columns throughout the approximately 275,000 square feet of floor area.

Maximizing efficiency in use of ground space in a relatively densely populated area, the garage has a capacity of 780 cars, about 156 on each of its five parking decks.

The building's character derives from its simple and elegant structural system and the fact that it makes maximum use of the prefabricated nature of its components.



Dallas 214.358.0174
Austin 512.469.9490
www.datumengineers.com



The Beginning of the Contemporary Precast Concrete Garage



Exterior Elevation



"Stack Walls"
Along the Ramp Under Construction

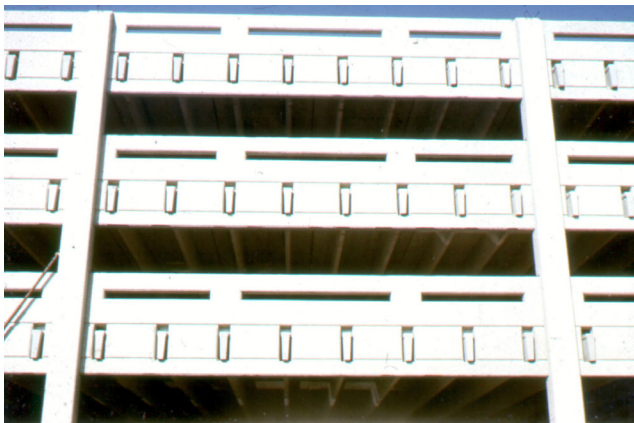

Unique Double Tee Support
Used at the Exterior Spandrel Beams

Baylor Hospital Parking Garage

Dallas, Texas

1974

In 1974, Datum Engineers conceived a new concept for constructing precast concrete garages for a new parking garage at Baylor Hospital in Dallas, Texas for **HKS Architects**.

Precast concrete walls ("stack walls") were utilized for the first time to support the sloping ramp floor on one side and the horizontal floor on the opposite side.

This system was recognized by the **Prestressed Concrete Institute** with a National Design Award in 1976 and the rest is history.

Thirty-five years later, this system is the most recognized precast concrete garage system used by the precast industry in new garage construction.

The \$5.25 per square foot initial cost for the completed structure was impressive, even in 1974. Even more impressive is the low maintenance required over the years and the good condition of the structure thirty-five years later.

Datum Engineers continued in the 1980's to improve and refine the precast concrete system developed for Baylor Hospital which was successfully used on large garages throughout Texas.



Continuing Design Excellence In the 1980'S



In addition to continued design of precast garages, Datum Engineers began to focus on the possible long-term durability of post-tensioned concrete garages if proper attention is given to certain critical details.

Las Colinas Garage

Datum's work with post-tensioned concrete garage construction was first recognized in 1981 by the **Post-Tensioning Institute** with a National Design Award for Williams Square Parking Garage in Las Colinas Irving, Texas designed by **SOM**, San Francisco.

This garage is all cast-in-place post-tensioned concrete. Four levels were constructed below grade and four levels above grade. We continue to monitor the condition of this garage almost thirty years later and are pleased to see how well it has performed.



Williams Square Garage



The National Parking Garage Disaster of the 1980'S



In the late 1980's and continuing into the 1990's there had been such a rash of deteriorated and failed parking garages that **Engineering News Record** wrote a cover story about it, and a whole new industry of parking garage repair contractors was born.

Datum was commissioned to investigate premature deterioration on many garages and we were surprised to see how extensive and widespread deterioration was in garages that were only several years old.

We observed designs and construction techniques that failed to respond satisfactorily when exposed to the weather. Many of these problems could have been avoided by simple attention to details. Most of these garages still exist. Some probably pose a life safety threat and others are still in existence due to exhaustive and expensive annual maintenance.

The alarming occurrence in the garage construction industry led Datum Engineers to write this design manual to cover design, specification, and construction issues that needed to be properly implemented in all types of garage construction including steel, precast and cast-in-place structures.



Years Later, We Continue To Improve



**University of Texas Brazos Garage
Austin, Texas**



**Parkland Memorial Hospital
Dallas, Texas**



**EDS Corporate Headquarters
2 Corporate Garages - 3 Cluster Garages
Plano, Texas**

Every new project continues to offer us the challenge to improve on previous details and specifications; to find more economical solutions; and to build longer lasting, lower cost garages.

We often muse at the many improvements we have made to our design manual over the years, considering how thoroughly we thought we had everything addressed in the original publication.

Our years of experience of innovation and implementation of the art of engineering parking garages, combined with the intensity and effort that we have put into perfecting this building type uniquely qualifies us to design the structure for your next garage.

We look forward to the opportunity to serve you.

Parking Structures

Union on 24th

Austin, Texas
Design Architect: Perkins&Will
30 stories
765,000 sq. ft. student housing and amenities
200,000 sq. ft. garage
\$158 Million
2023

CoverMyMeds Headquarters

Columbus, Ohio
Design Architect: Perkins&Will
Two buildings, each 400,000 sq. ft. headquarters located on the river. Includes boat house, bike ramps, 4-level garage, 1350 parking spaces
\$120 Million
2021

5th & Red River - Stonelake

Austin, Texas
Design Architect: Gensler
New 296,000 sq. ft. residential tower
36-levels above garage, 450 ft. tall
Includes 112,000 sq. ft. garage
2024

McKinney Municipal Complex

McKinney, Texas
Design Architect: Lake Flato
Architect of Record: Parkhill
New 210,000 sq. ft. building
600 parking spaces
\$90 Million
2022

Tempe Surfe Office Building

Austin, Texas
Design Architect: Studio 8
New 30,000 sq. ft office building, 3-level garage for 110 parking spaces
\$12 Million
2023

St. Austin's Student Housing Tower & Garage

Austin, Texas
Design Architect: Page
New 30-story tower, 421,000 sq. ft.
6-level garage, 200,000 sq. ft.
2023

Fortis Garage

Dallas, Texas
Design Architect: Omniplan
205,000 sq. ft.
11.5 levels for 500 parking spaces
2021

TxDOT Headquarters Campus

Austin, Texas
Design Architect: Marmon Mok
5-story, 425,344 sq. ft. office, 131,250 sq. ft. warehouse, 84,134 sq. ft. materials lab, radio & signal testing lab, 13,094 sq. ft. central plant, and a 6-level, 539,300 sq. ft. parking garage for 1,581 cars
\$308 Million
2021

Bexar County Garage

San Antonio, Texas
Architect: RVK
Contractor: Joeris
Design Build
4 levels, 220,000 sq. ft., 626 parking spaces
2021

The Hallmark Tower

Houston, Texas
Design Architect: Perkins Eastman
600,000 sq. ft.
32 story senior citizens residential tower
32 levels above grade, 1 below
3 level garage, 437 parking spaces
2020

Parkland Maple Avenue Garage

Dallas, Texas
Design Build: Beck
1400 car parking structure, one-way post tensioned concrete beam and slab framing
Includes new connector bridge between garage and the new clinic. Cast-in-place concrete
\$29 Million
2020

San Antonio Zoo Garage

San Antonio, Texas
Design Architect: Alamo Architects
Contractor: Guido Construction
Design Build, Precast concrete, 600 parking spaces
\$10.1 Million
2020

Texas A&M University Polo Road Garage

College Station, Texas
Design Architect: PGAL
Contractor: SpawGlass
Design Build, 5 levels, 2100 parking spaces
600,000 sq ft., includes 70,000 sq. ft.
Exercise facility, dining hall and office
\$47 Million
2020



Parking Structures

Park Cities Presbyterian Church

Dallas, Texas
Design Architect: Omniplan
63,000 sq. ft. expansion, 68,000 sq. ft. of renovation, 100 car underground garage
2020

MoonTower Student Housing

Austin, Texas
Design Architect: Gensler
18 level dorm, 536 beds, 275,000 sq. ft.,
4 level garage, 180 parking spaces
2019

ACC Highland Campus Garage

Austin, Texas
Design Architect: BGK Architects
New 2400 car garage, 7 levels, 800,000 sq. ft.
Cast-in-place concrete
\$40 Million
2019

Comerica Bank Garage Expansion

Dallas, Texas
Design Architect: Ziegler Cooper
950 parking spaces, 7-level expansion to existing
7-level garage
\$18 Million
2019

Omni Barton Creek

Austin, Texas
Architect/Contractor: The Beck Group
Resort makeover included a new 493 room hotel tower, 52,237 sq. ft. conference center with two ballrooms and 16 meeting rooms, 5,556 sq. ft. pavilion with indoor/outdoor space for special events, golf clubhouse, tennis complex with 10 courts, 7 new restaurants, a 13,000 sq. ft. spa and wellness center, and a 140,000 sq. ft. garage for 430 cars.
\$150 Million
2019

Verizon Parking Garage

Irving, Texas
Design/Build: Beck
New 450 car garage
\$20 Million
2019

Oak Grove Hotel

Dallas, Texas
121,000 sq. ft.
21-story hotel & 7-level garage
2018

UTSW Radiation Oncology

Heavy Ion Treatment & Research Center

Dallas, Texas
Design Architect: Perkins&Will
650 parking spaces
\$14 Million
2018

UT East Campus Garage

Austin, Texas
Design Architect: PGAL
Contractor: SpawGlass
Design Build, 614,000 sq. ft. garage for 2,000 cars
7,000 sq. ft. support space, 15,000 sq. ft. office space
\$47 Million
2017

UT Arlington West Campus Garage

Arlington, Texas
Design Architect: Corgan
Contractor: Hensel Phelps
5 levels, 1500 spaces, cast-in-place, fast-track
\$25 Million
2017

UT Dell Medical School Health Center Garage

Design Architect: ZGF
Architect of Record: Page
4 story, 242,000 sq. ft. medical office building atop a 6 level, 440,000 sq. ft., 1120 car garage.
\$43 million MOB, \$23 million garage
2016

UTSW Radiation Oncology Garage

Dallas, Texas
Design Architect: Perkins&Will
450 parking spaces, 5 levels above grade
\$10 Million
2016

TCU Frog Alley Garage

Fort Worth, Texas
Architect: Beck Architecture
Contractor: The Beck Group
306,000 sq. ft., 3 levels above grade & 1 level below. 4 levels, 1700 parking spaces
\$15 Million
2015

Fidelity Garage Phase 2 One Destiny Way Expansion

Westlake, Texas
Design Architect: HKS
440 parking spaces
2015



Parking Structures

UTD Garage Phase 3

Richardson, Texas
Design Architect: Omniplan
266,000 sq. ft., 15,000 sq. ft. retail,
5 levels, 750 parking spaces
\$10.5 Million
2014

Parkland Hospital Garage

Dallas, Texas
LEED Gold
Architect: Omniplan
732,800 sq. ft., 1688 parking spaces
\$27 Million
2013

UNT Business Leadership Building Garage

Denton, Texas
Design Architect: Ennead
Architect of Record: Jacobs
900 parking spaces
\$17 Million
2012

Las Colinas Live Garage

Irving, Texas
Architect: RMJM Hillier
4 levels, 850 parking spaces
\$15 Million
2009

ACC Rio Grande Campus Garage

Austin, Texas
Architect: Barnes Gromatzky Kosarek
191,000 sq. ft., 7 levels, 543 parking spaces
\$11 Million
2009

SMU Binkley Garage

Dallas, Texas
Architect: Good Fulton & Farrell
5 levels, 850 parking spaces
\$9 Million
2008

Austin Presbyterian Theological Seminary Dormitory Garage

Austin, Texas
Architect: O'Connell Robertson
10,000 sq. ft. garage below student housing
2008

St. Edward's University Student Housing Garage

Austin, Texas
Free standing garage for 600 cars.
2008

UT San Antonio Street Garage Expansion

Austin, Texas
Design Architect: O'Connell Robertson
Contractor: SpawGlass
Design Build, 95,784 sq. ft. addition of 2 levels on
existing 5 level garage, 315 additional spaces
\$6.88 Million
2008

Fidelity Garage - Two Destiny Way

Westlake, Texas
Design Architect: HKS
838,000 sq. ft., 2600 parking spaces
2007

Crow Holdings at Old Parkland

Dallas, Texas
Design Architect: Good Fulton Farrell
Renovation of 56,000 sq. ft. historic Woodlawn
Hospital. 2 levels below grade garage and a
2 level office building addition
2007

Domain Shopping Center Garages

Austin, Texas
Architect: Beck Architecture
Contractor: The Beck Group
Design Build, 2 Precast concrete parking
structures for 6 levels (2 below grade), 720,000 sq.
ft., 2 levels, 105,000 sq. ft., 2400 parking spaces
\$19 Million
2006

NorthPark Office Development Garage

Dallas, Texas
2 levels below grade
2006

Fidelity Garage Phase 1 One Destiny Way

Westlake, Texas
Design Architect: HKS
300 parking spaces
2005

Macy's Garage at NorthPark Center

Dallas, Texas
Architect: Omniplan
Northeast Deck
5 levels, 1700 parking spaces
2004



Parking Structures

Nordstrom Garage at NorthPark Center

Dallas, Texas
Design Architect: Omniplan
Northwest Deck - 5 levels, 1700 parking spaces
2005

DPL Garage

Dallas, Texas
4 levels (1 below grade), 150 parking spaces
2005

Lower Colorado River Authority Garage Expansion

Austin, Texas
Added 1 level to existing 2 level garage,
170 parking spaces, 53,000 sq. ft.
2004

Deerfield Senior Living Center

Des Moines, Iowa
Design Architect: GSC Architects
157 parking spaces
2004

UTSW Phase 4 Garage

Dallas, Texas
4 levels, 231 parking spaces, 96,165 sq. ft.
2004

Austin City Hall Underground Garage

Austin, Texas
Design Architect: Antoine Predock
Architect of Record: Cotera+Reed
3 levels, 750 parking spaces, 275,000 sq. ft.
2003

Region XIII Conference & Technology Center Garage

Austin, Texas
3 levels, 300 parking spaces
2003

Capitol Chevrolet

Austin, Texas
4 levels, 250 parking spaces, 132,000 sq. ft.
2001

Research Park Lot 11

Austin, Texas
2 levels, 125,000 sq. ft.
2001

Bank One Office Building

Fort Worth, Texas
11 levels, 775 parking spaces, 253,000 sq. ft.
2001

The Eisemann Center

Richardson, Texas
6 levels, 1 below grade, 750 parking spaces,
270,000 sq. ft.
2001

Mira Vista

Austin, Texas
110,000 sq. ft., 4 levels, 525 spaces in 2 garages
2001

River Place Pointe Garage 2

Austin, Texas
Design Architect: GSC Architects
304,000 sq. ft., 4 levels, 715 parking spaces
\$6.2 Million
2000

Fidelity Garage - One Destiny Way

Westlake, Texas
Design Architect: HKS
5 levels, 2440 parking spaces
2000

River Place Pointe Garage 1

Austin, Texas
Design Architect: GSC Architects
4 levels, 1100 parking spaces, 450,000 sq. ft.
\$7.76 Million
2000

Texas Trial Lawyers Association

Austin, Texas
Design Architect: STG Design
5 levels, 169 parking spaces, 68,000 sq. ft.
2000

Research Park Plaza Garage

Austin, Texas
5 levels, 780 parking spaces, 250,000 sq. ft.
Precast Concrete
1999

State Visitor's Garage

Austin, Texas
Design Architect: Harry Goleman Architects
3 levels (1 below grade), 750 parking spaces
\$9 Million
1999

Centura Tower

Dallas, Texas
11 levels, 468,634 sq. ft.
1999



Parking Structures

The Overlook at Gaines Ranch Office Building

Austin, Texas
66,000 sq. ft.
2.5 levels (1 level below grade)
157 parking spaces
1998

UT Brazos Garage

Austin, Texas
Design Architect: Taniguchi & Associates
8 levels (1 below grade), 1600 parking spaces.
500,000 sq. ft., precast concrete with brick exterior. Lowest level excavated into hillside, external cantilevering stairs, and external elevator core.
\$8.9 Million
1997

Brown Building Lofts

Austin, Texas
4 levels (1 below grade)
\$1.6 Million
1997

Texas A&M Central Campus Garage

College Station, Texas
Design Architect: GSC Architects
208,840 sq. ft., 7 levels, 635 parking spaces
Cast-in-place
\$7.2 Million
1996

Quarry Lake Business Center Garage

Austin, Texas
1996

Atlanta Medical Office Building Garage

Atlanta, Texas
1 level, 16 parking spaces
1996

Avallon Development Phase 2 Garage

Austin, Texas
4 levels, 350 parking spaces. Precast Concrete
1996

UTSW Phase 2 Garage

Dallas, Texas
2 levels, 180 parking spaces. Cast-in-Place
1995

Barton Oaks 4 Garage

Austin, Texas
3.5 levels, 117,000 sq. ft.
1995

Plaza Fiesta San Agustín North Garage

Monterrey, Mexico
1 level, 160 parking spaces
1995

UTSW Phase 1 Garage

Dallas, Texas
1 level, 170 parking spaces, Cast-in-Place
1994

Dillard's Garage at NorthPark Center

Dallas, Texas
4 levels, 800 parking spaces, Precast Concrete
1994

Mazda Motors Hail Protection Garage

Midlothian, Texas
1,200,000 sq. ft., 1 level, 5000 parking spaces
\$1.2 Million
1994

Texas State Capitol Extension Garage

Austin, Texas
2 levels, 700 parking spaces, 330,000 sq. ft.
Cast-in-Place
1993

Exxon Corporate Headquarters

Irving, Texas
4 levels, 400 parking spaces
1994

Federal Reserve Bank of Dallas

Dallas, Texas
277,000 sq. ft., 3 levels, 775 parking spaces
Post-Tensioned Concrete
1993

LCRA Headquarters Garage

Austin, Texas
106,000 sq. ft., 2 levels, 313 parking spaces
Precast Concrete
1993

EDS Corporate Headquarters

Plano, Texas
2,600,000 sq. ft., two 5 level garages,
9200 parking spaces
Precast Concrete
1993



Parking Structures

Parkland Medical Center Drive Garage Exp.

Dallas, Texas
160,000 sq. ft. addition, 2 levels, 450 spaces
\$4 Million
1993

Parkland Medical Center Drive & Laundry

Dallas, Texas
425,000 sq. ft., 4 levels, 1000 parking spaces
1993

GTE Telops Headquarters

Irving, Texas
1,000,000 sq. ft., 3 levels, 3200 parking spaces
Post-Tensioned Concrete
1991

Parkland Memorial Hospital Lofland Street Garage

Dallas, Texas
6 levels, 1100 parking spaces, 350,000 sq. ft.
Post-Tensioned Concrete
1990

GTE Place 2

D/FW International Airport
Precast Concrete, 3 levels, 400 parking spaces
1986 - 1989

Cityplace

Dallas, Texas
6, 7 & 9 levels, 3,400 parking spaces,
2,500,000 sq. ft., Post-Tensioned Concrete
1989

Comerica Bank Tower

Dallas, Texas
4 levels
1989

BMW Vehicle Processing Center

Port Jersey, New Jersey
Precast Concrete, 3 levels, 1800 parking spaces
1988

BMW Vehicle Processing Center

Oxnard, California
Precast Concrete, 2 levels, 1000 parking spaces
1988

EDS Cluster 3

Plano, Texas
2 levels, 420 parking spaces
1988

EDS Cluster 2

Plano, Texas
Precast Concrete, 3 levels, 420 parking spaces
1985

EDS Cluster 1

Plano, Texas
Precast Concrete, 3 levels, 420 parking spaces
1985

First City Center 2

Dallas, Texas
12 levels, 1100 parking spaces
1987

Decker Correction Center

Dallas, Texas
7 levels, 220 parking spaces
1987

Atlantic Center IBM Tower

Atlanta, Georgia
Cast-in-Place Concrete, 8 levels, 1400 spaces
1990

Metro 2

Dallas, Texas
3 levels
1986

Two American Center

Tyler, Texas
5 levels, 400 parking spaces
1986

Belo Corporation Headquarters

Dallas, Texas
3 levels
1986

10,000 North Central

Dallas, Texas
4 levels
1987

Highpoint Center

Dallas, Texas
8 levels
1985

Shepherd Mountain Complex

Austin, Texas
4 levels, 314 parking spaces
1985



Parking Structures

Republic Plaza

Austin, Texas
2 levels
1985

Republic Bank Plaza

San Antonio, Texas
1 level
1985

Terminal 2ED

D/FW International Airport
4 levels, 1800 parking spaces
1985

One American Center

Austin, Texas
10 levels
1985

Arco Research & Development

Plano, Texas
3 levels, 600 parking spaces
1984

Terminal 2EC

D/FW International Airport
8 levels, 1800 parking spaces
1984

Terminal 2EB

D/FW International Airport
8 levels, 1800 parking spaces
1984

First City Centre

Austin, Texas
9 levels, 450 parking spaces
1984

American Airlines Terminal 3EC

D/FW International Airport
4 levels, 1800 parking spaces
1983

Delta Airlines Terminal 4EC

D/FW International Airport
5 levels, 1800 parking spaces
1983

First City Center

Dallas, Texas
12 levels, 1420 parking spaces
1983

Southwestern Bell Plaza

Dallas, Texas
10 levels, 1000 parking spaces
1984

Williams Square Office Building

Irving, Texas
6 levels, 3600 parking spaces
1983

Good Samaritan Hospital

Lexington, Kentucky
4 levels, 400 parking spaces
1983

7557 Rambler Road

Dallas, Texas
3 levels, 600 parking spaces
1982

City of Austin Police Department

Austin, Texas
6 levels, 260 parking spaces
1982

City of Austin Police Addition

Austin, Texas
3 levels, 325 parking spaces
1982

St. Paul Tower

Dallas, Texas
5 levels
1983

Westchase

Houston, Texas
7 levels, 1800 parking spaces
1981

Towers East Office Building Garage

Irving, Texas
Design Architect: HKS
9 levels, 1400 parking spaces
1981

BlueCross BlueShield Garage

Richardson, Texas
4 levels, 1000 parking spaces
1981

Four Seasons Hotel Garage

Irving, Texas
3 levels
1980



Parking Structures

Harwood Center Garage

Dallas, Texas
6 levels, 600 parking spaces
1982

Jewish Hospital Garage

Cincinnati, Ohio
6 levels, 600 parking spaces
1980

Bright Bank Tower Garage

Dallas, Texas
8 levels
1978

NorthPark Center Garage

Dallas, Texas
2 levels, 800 parking spaces
1976

Baylor Medical Center Garage

Dallas, Texas
5 levels, 1000 parking spaces
1974

Woodward & Lathrop Garage

Montgomery County, Maryland
4 levels, 900 parking spaces
1975

Great American Reserve Garage

Dallas, Texas
3 levels, 600 parking spaces
1970

Earle Cabell Federal Center Garage

Dallas, Texas
3 levels
1968



San Antonio Zoo Garage

San Antonio, Texas

Design Architect: Alamo Architects

Contractor: Guido Construction

Design Build, 600 parking spaces

\$10.1 Million

2020



Parkland Maple Avenue Garage

Dallas, Texas

Design Build: Beck

1400 car parking structure, one-way post tensioned concrete beam and slab framing. Includes new connector bridge between garage and the new clinic. Cast-in-place concrete.

\$29 Million

2020



Parkland Hospital Garage

Dallas, Texas

Design Architect: Omniplan

Contractor: Whiting Turner

LEED Gold

Design Build

732,800 sq. ft. / 1,688 parking spaces

2013



ACC Highland Campus Garage

Austin, Texas

Design Architect: BGK Architects

New 2400 car garage / cast-in-place concrete / 7 levels / 800,000 sq. ft.

\$40 Million

2019



UT East Campus Garage

Austin, Texas

Design Architect: PGAL

Contractor: SpawGlass

636,000 sq. ft.

\$47 Million

2017

UT Austin needed a 2,000 car garage to provide much-needed parking for the campus and future graduate student housing. Datum worked as part of a design-build team which delivered the first 1,200 spaces in less than 24 months, with an additional 800 spaces just 4 months later. We worked closely with the construction team to design around existing conditions (such as the adjacent to Disch-Falk baseball field), site construction constraints on an active campus, and long-lead items. The design of the post-tensioned elements was coordinated with the pour sequences and tendon pulls to speed construction while providing a very low maintenance structural solution.



TCU Frog Alley Garage

Fort Worth, Texas

Design Architect: Beck

2016 Best of Precast Concrete Award - Mid-Size Parking Garage

306,000 sq. ft. / 3 levels above grade & 1 level below / 4 level garage / 1,700 parking spaces

\$15 Million

2015



Fortis Garage

Dallas, Texas

Design Architect: Omniplan

205,000 sq. ft.

11.5 levels / 500 parking spaces



UNT Business Leadership Garage

Denton, Texas

Design Architect: Ennead

Architect of Record: Jacobs

900 parking spaces

2012



Texas A&M University Polo Road Garage

College Station, Texas

Design Architect: PGAL

Contractor: SpawGlass

Design Build / 5 levels / 2100 parking spaces / 600,000 sq. ft.

70,000 sq. ft. exercise facility, dining hall and office

\$47 Million

2020



UTD Parking Garage

Richardson, Texas

Design Architect: Omniplan

281,000 sq. ft.

\$10.5 Million

2014

The new University of Texas Dallas parking garage is a 5 level parking structure that serves students and visitors at the Richardson, Texas campus. The design of this parking structure incorporates a mixed-use occupancy with the final structure housing university offices, restaurants, and vehicular parking.

The parking design had to incorporate future restaurants and an unloading dock on the ground level. The owner requested the loading dock be column free to prevent the risk of trucks hitting and damaging the structure. To respond to this request Datum designed a 2 story cantilever structure to span across the dock area.

To increase the natural lighting in the structure upturn perimeter beams were designed to allow natural light in and also hide the cars from view when walking through the campus. This increase in natural light aids in user comfort and security.



Hidden Ridge Garage

Irving, Texas

Design Architect: Beck

2019 Best of Precast Concrete Awards - Small-Size Parking Garage

144,000 sq. ft. / 3 level garage / 437 parking spaces

\$9 Million

2018



NorthPark Center Garages G1 & G2

Dallas, Texas

Design Architect: Omniplan

3400 parking spaces

2005



SMU Binkley Garage

Dallas, Texas

Design Architect: Good Fulton & Farrell

5 levels / 850 parking spaces

2008



Baylor Hospital Parking Structure

Dallas, Texas

Design Architect: Harwood K. Smith & Partners

5 parking decks / 780 parking spaces

TOP 50

The 50 Most Significant Precast Concrete Projects

Precast/Prestressed Concrete Institute's members select the 50 projects that have most impacted the design and construction industries.

INDUSTRY



ACC Rio Grande Garage

Austin, Texas

Design Architect: BGK Architects

Architect: Barnes Gromatzky Kosarek

191,000 sq. ft. / 7 levels / 543 parking spaces

Austin Energy 2-Star Rating

\$11 Million

2009

90 percent of construction materials came from within Texas, reducing transportation expenses, fuel consumption, and pollution.

Construction materials included 40 percent recycled content.

A south-facing glass storefront reduces the need for electric lighting and saves energy.



UT Arlington West Campus Student Garage

Arlington, Texas

Design Architect: Corgan

Contractor: Hensel Phelps

2018 Texas Parking & Transportation Association Award of Excellence - Parking Structure - New Design Build

5-level garage / 1,500 parking spaces

\$25 Million

2017



UT San Antonio Street Garage Expansion

Austin, Texas

Design Architect: O'Connell Robertson

Addition of 2 levels on existing 5 level garage 315 additional cars

95,784 sq. ft.

\$6.88 Million

2008



UT Brazos Garage

Austin, Texas

Design Architect: Taniguchi & Associates

8 levels / 1 below grade / 1600 parking spaces

500,000 sq. ft., precast concrete with brick exterior.

Lowest level excavated into hillside, external cantilevering stairs, and external elevator core.

\$8.9 Million

1997



Texas State Capitol Visitor's Garage

Austin, Texas

Design Architect: Harry Goleman Architects

3 levels / 1 below grade / 750 parking spaces

\$9 Million

1999



Towers East Garage

Irving, Texas

Design Architect: HKS

9 levels / 1400 parking spaces

1981



Williams Square Garage

Irving, Texas

Design Architect: SOM San Francisco

6 levels / 3600 parking spaces

1983



Texas A&M University Evans Library Garage

College Station, Texas

Design Architect: GSC Architects

208,840 sq. ft. / 7 levels / 635 parking spaces

Cast-in-Place

\$7.2 Million

1996



EDS World Headquarters Garage

Plano, Texas

Design Architect: HKS

Two 5 level garages / 9200 parking spaces

2,600,000 sq. ft.

Precast Concrete

1993



Cityplace Tower Garage

Dallas, Texas

Design Architect: Cossutta & Associates

3,400 parking spaces

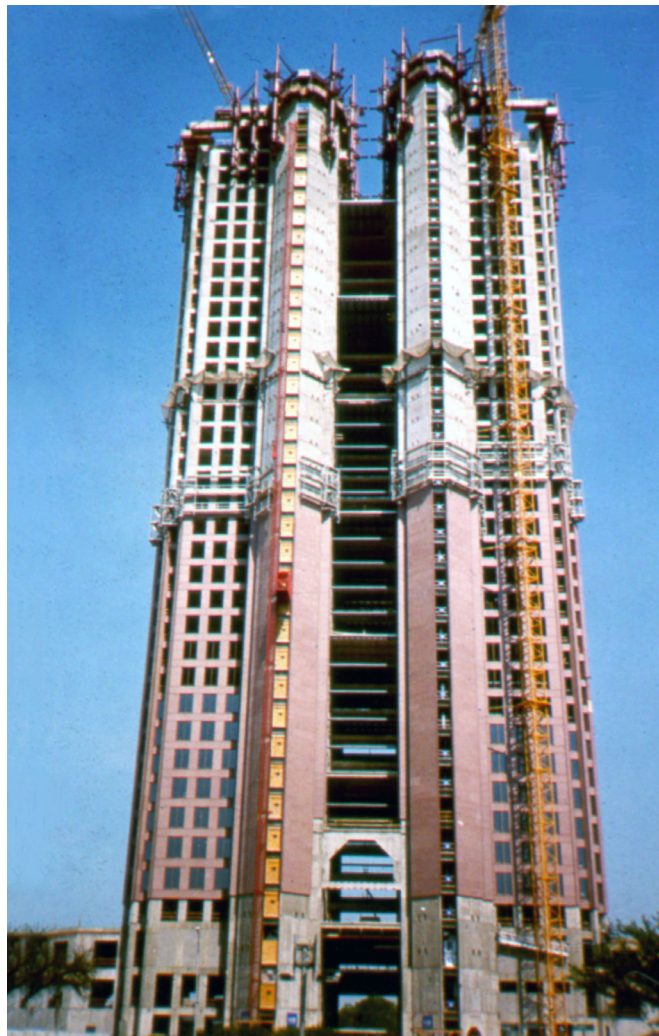
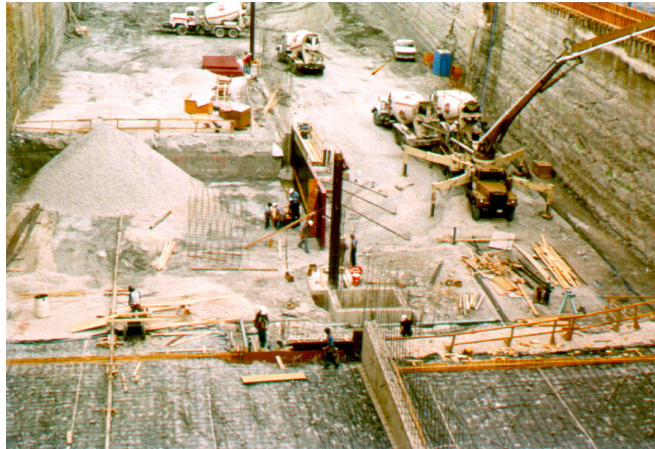

DFW International Airport Garage

Dallas / Fort Worth International Airport, Texas

Design Architect: HLM Design

5 parking garages / 1800 parking spaces





Structural Systems 2

CHAPTER 2

STRUCTURAL SYSTEMS

Open parking structures have been designed and built with a wide assortment of structural systems. These systems are usually one of the following:

1. **TOPPED PRECAST CONCRETE:** Precast concrete columns, beams, and double tees with a 2 to 3 inch cast-in-place concrete topping.
2. **UNTOPPED PRECAST CONCRETE:** Precast concrete columns, beams, and double tees without cast-in-place concrete topping. Joints are sealed with waterproofing material.
3. **POST-TENSIONED BEAM AND SLAB:** Post-tensioned, cast-in-place concrete beams and slabs supported on concrete columns and walls.
4. **POST-TENSIONED PAN JOIST:** Post-tensioned, cast-in-place concrete pan joists spaced 3 to 5 feet apart, with a thin slab.
5. **PRECAST FRAME WITH FORMED SLAB:** Post-tensioned, cast-in-place formed slab on a framework of precast concrete beams and columns.
6. **STEEL FRAME WITH FORMED SLAB:** Post-tensioned, cast-in-place formed slab on a framework of steel beams and steel columns.
7. **STEEL FRAME WITH METAL DECK:** Cast-in-place concrete slab on metal deck, on a framework of steel beams and steel columns. (Not recommended.)
8. **STEEL JOIST WITH METAL DECK:** Cast-in-place concrete slab on metal deck, steel bar joists, steel beams and columns. (Not recommended.)
9. **CONVENTIONALLY REINFORCED CONCRETE FRAME:** Cast-in-place concrete slab and beam joist flat plate or flat slab on concrete columns, with normal mild reinforcing. (Not practical for long spans.)

Systems one through six are reasonable framing solutions for long-span open parking structures. These systems are discussed in detail in Chapters 3 through 8 of this report.

Systems seven through nine are not recommended for long span open garages. Reasons for this are covered in Chapter 9. These structural systems are not discussed in detail in this report.

Factors of Evaluation - In Chapters 3 through 8, each of the six structural systems is examined with regard to the following categories:

- A. Description.**
- B. Advantages.**
- C. Disadvantages.**
- D. Recommended Details.**
- E. Key Specification Items.**
- F. Discussion of Problems and Proposed Solutions:**
 1. Fabrication and erection tolerances.
 2. Environment related problems.
 3. Construction related problems.
 4. Design related problems.
 5. Maintenance related problems.
- G. Maintenance Requirements.**
- H. Cost Estimates for Quantities a Sample Project:**
 1. Construction.
 2. Maintenance.



Topped Precast Concrete 3

CHAPTER 3

TOPPED PRECAST CONCRETE

A. DESCRIPTION

Precast concrete columns, beams, and double tees with a 2” to 3” cast-in-place concrete topping. This is the most common type of precast garage.

B. ADVANTAGES

Economical - Most of the concrete casting is done in repetitive fashion in the precast plant under controlled conditions. There is only a small amount of forming, reinforcing, and concrete casting done in the field.

Rapid Construction - Members can be prefabricated in the precast plant at the same time that the foundation is being constructed. Normally, erection is very rapid.

All-Weather Construction - Adverse weather does not hinder erection or fabrication as much as it does with cast-in-place construction.

Eliminates Formwork - Formwork in the field is essentially eliminated. The tee becomes a working surface and permanent form for the cast-in-place concrete topping.

Appearance - Architectural finishes are more consistent. Plant fabrication provides for easier and more consistent forming and better quality control than is possible in the field.

Proper Tendon Placement - Plant fabrication provides more accurate tendon placement and stressing than can be accomplished in the field with post-tensioning. Bonded strands are protected indefinitely by the concrete cast against them, whereas unbonded tendons used in post-tensioning are susceptible to corrosion if water and salt enter the sheathing.

Durability - Precast members have a more durable finish. Typically, they are cast with higher strength concrete and are often prestressed. Prestressing compresses the member both to minimize and to reclose cracks if they occur.

Concrete Quality - There is a better chance of maintaining consistent concrete quality in a precast plant than can be obtained in the field. Water/cement ratio, air quantity, and reinforcing cover are better controlled.

Proper Curing - Concrete cast in the fabrication plant can be properly steam cured, resulting in a better quality concrete than can be accomplished in the field. Steam curing is much more effective than other types of curing.

C. DISADVANTAGES

Joints - Although extremely difficult, numerous control joints must be immediately tooled into the topping while the concrete is still in its plastic state. This tooling process requires more finishers, often working into the night. However, this is necessary to control cracking in the thin topping directly over the joints between precast units. If not tooled, random irregular cracks will occur due to differential curing and shrinkage. Sawcutting control joints later is of no benefit because square edges tend to spall and because it is often done too late to prevent shrinkage cracks. Often, even with extreme care, shrinkage cracks still occur outside of the tooled joint.

Sealing - The tooled joints must be cleaned, primed, and sealed to prevent water penetration.

Waterproofing - All levels must have a concrete sealer applied. The top level should have a silane based sealer or waterproofing membrane to protect cracks from moisture intrusion.

Connections - Connections must be oversized to allow for erection tolerances. Connection metals exposed to the weather must be hot-dip galvanized to protect them from the elements. Often, the galvanizing process delays the casting schedule because it involves another paint. Field welding of the connections destroys the galvanic coating, so the welded areas must be touched up with cold galvanizing compound. Other concealed or embedded plates must be epoxy painted and touched up after welding, using the same paint. Connections not detailed with enough flexibility will crack the concrete. Extra reinforcing must be provided at rigid connections to keep the cracks from opening up. Ideally, connections should be recessed and covered with grout or sealant.

Tolerances - Fabrication and erection must be within prescribed tolerances which historically have been difficult to meet.

Erection Problems - There are problems that arise during erection due to out-of-tolerance fabrication and poor erection practices. These include member misplacement, pad misplacement, rotation of members on pads, point bearing, loss of bearing, edges spalling, etc.

Less Adaptable - Precast construction allows less flexibility than cast-in-place systems for complex shapes, irregular sites, and curved ramps.

Lighting - Due to closely spaced double tee stems, lighting is not easily or efficiently accomplished. Light fixtures normally have to be placed up between the tee stems (and not below), due to headroom considerations. This reduces the effectiveness of each fixture.

Drainage - Compound drainage slopes are difficult to attain. High cambers tend to impair drainage.

D. RECOMMENDED DETAILS

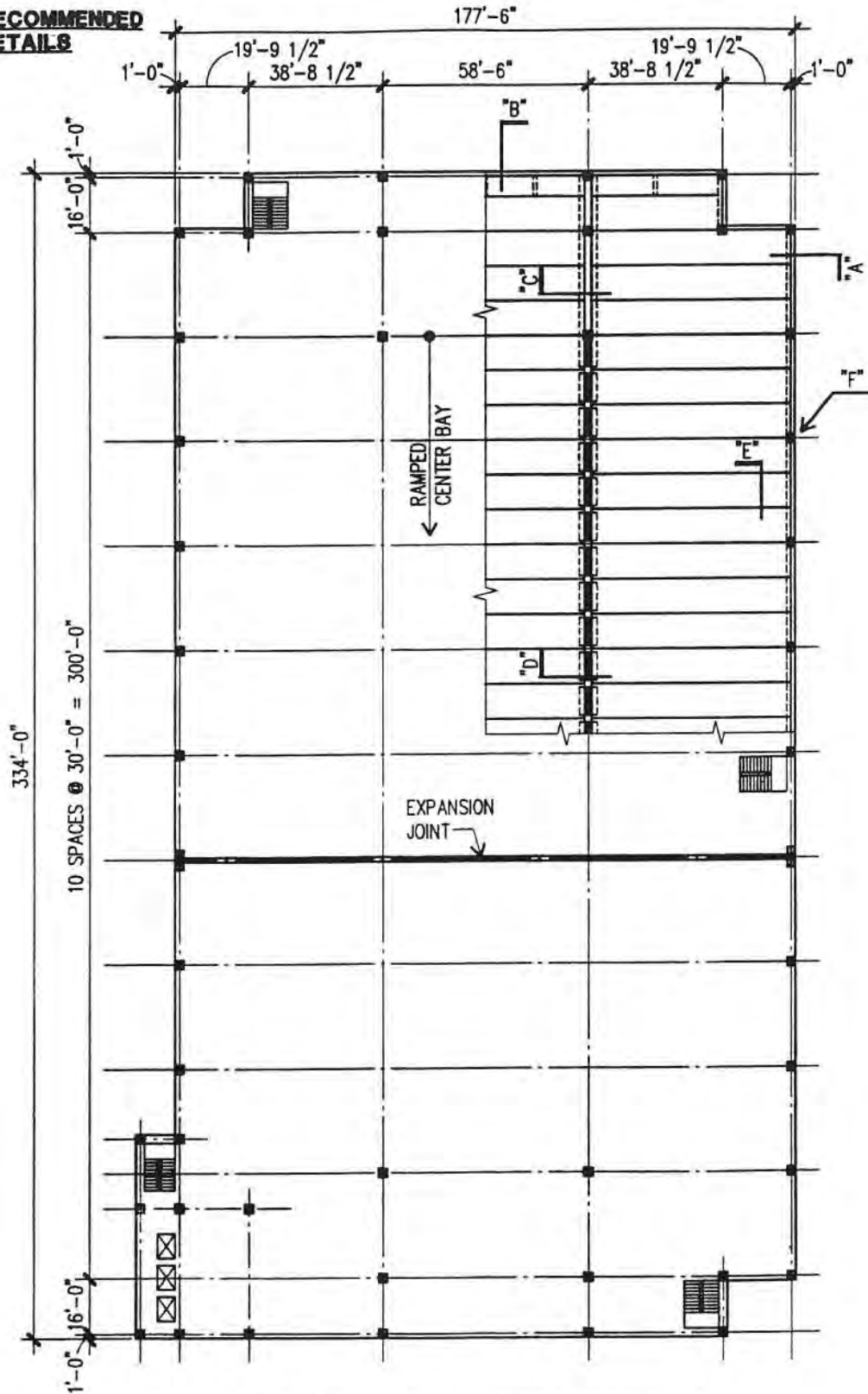

TYPICAL FLOOR FRAMING PLAN

1"=40'-0"

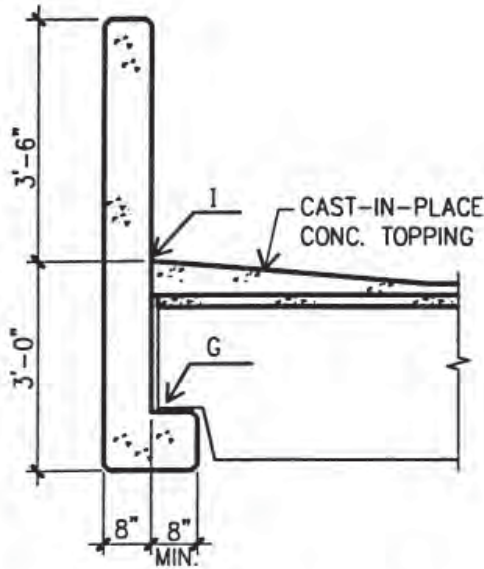

A TYPICAL PRECAST SPANDREL BEAMS

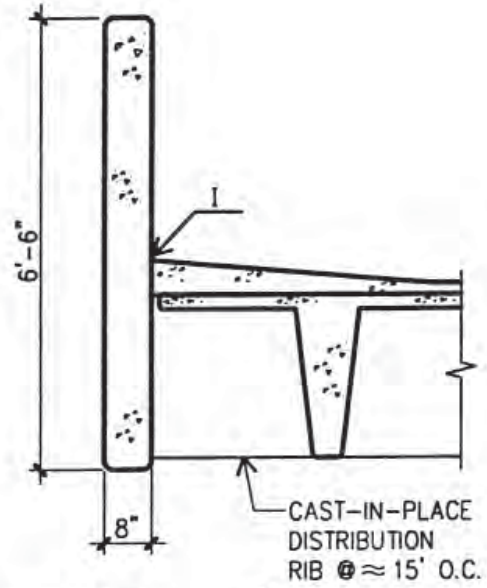

B

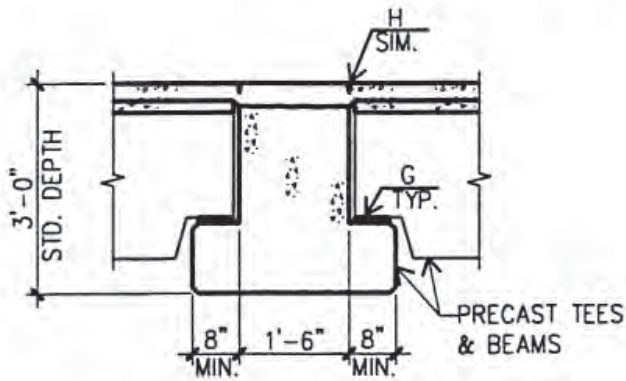

C TYPICAL PRESTRESSED INVERTED TEE BEAM

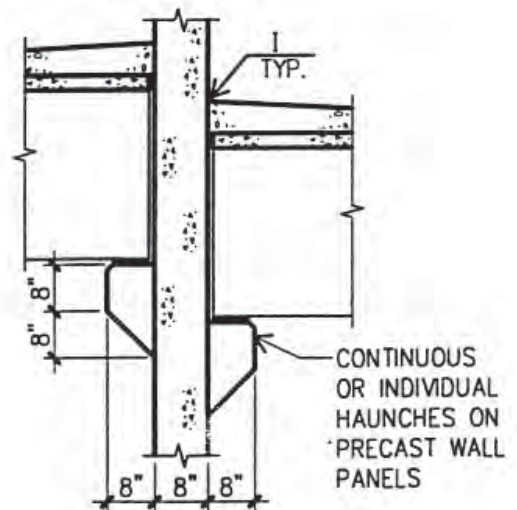

D TYPICAL INTERIOR WALL PANEL

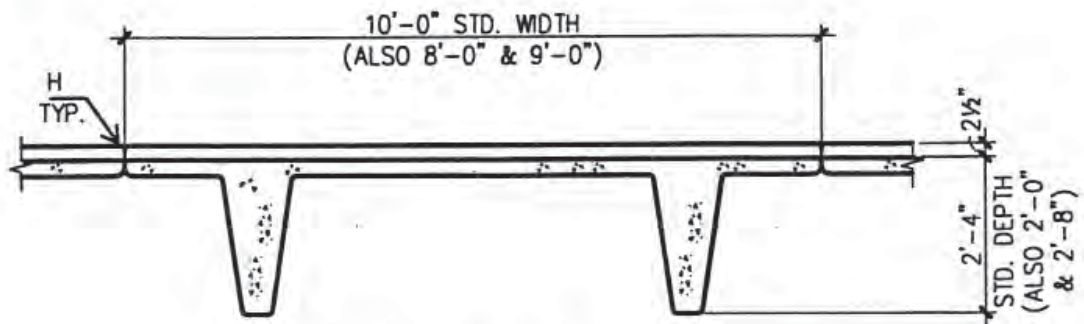

E TYPICAL DOUBLE TEE

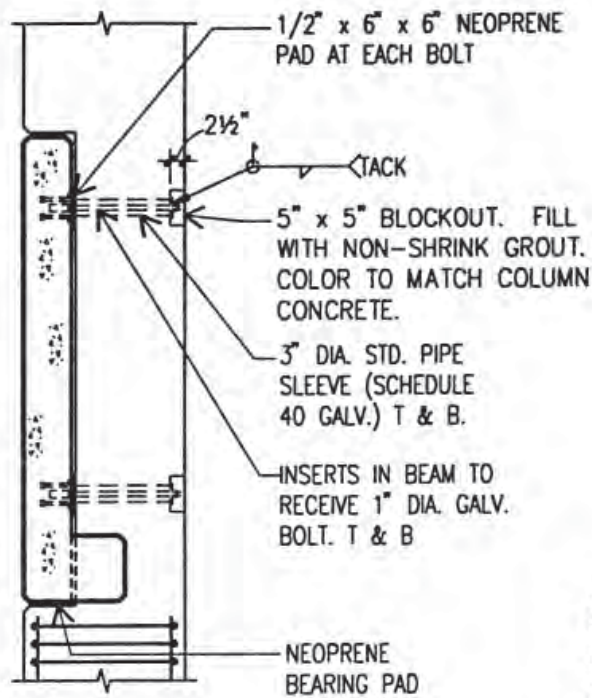

F

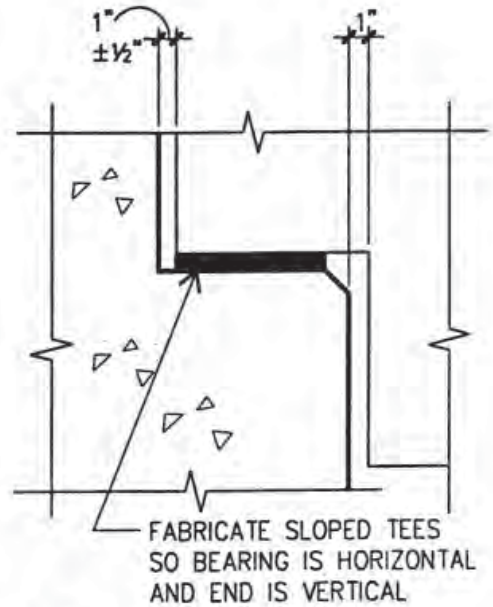

NOTE: WHEN TEE HAS BEEN SET IN PLACE ADJUST BEARING PAD IF REQUIRED, BEFORE RELEASING MEMBER. PAD MUST BE SET 1" FROM FACE OF LEDGE AS SHOWN IN THIS DETAIL.

G

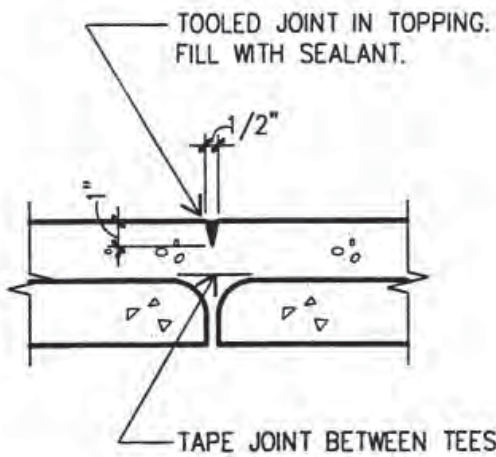

H

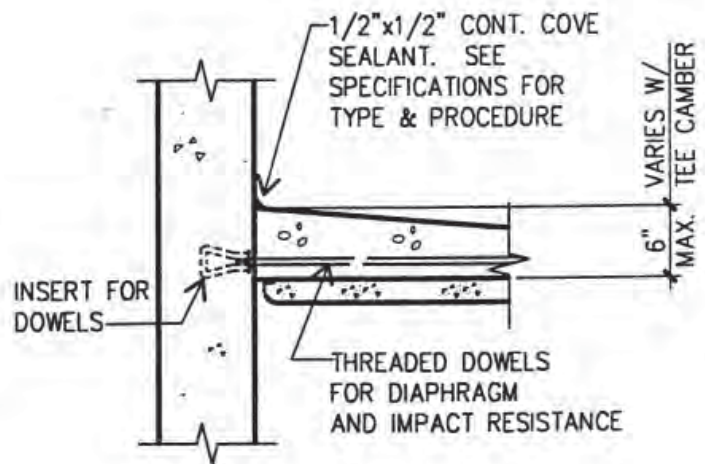

I

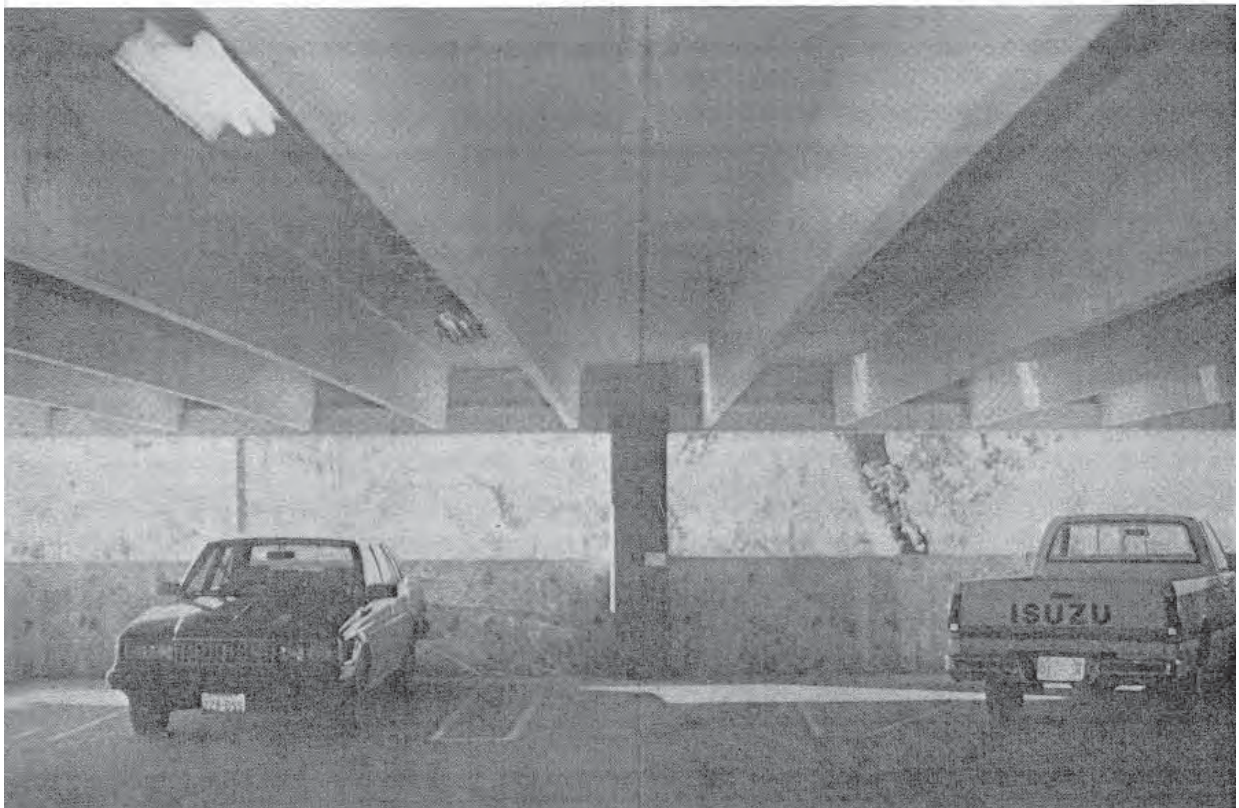
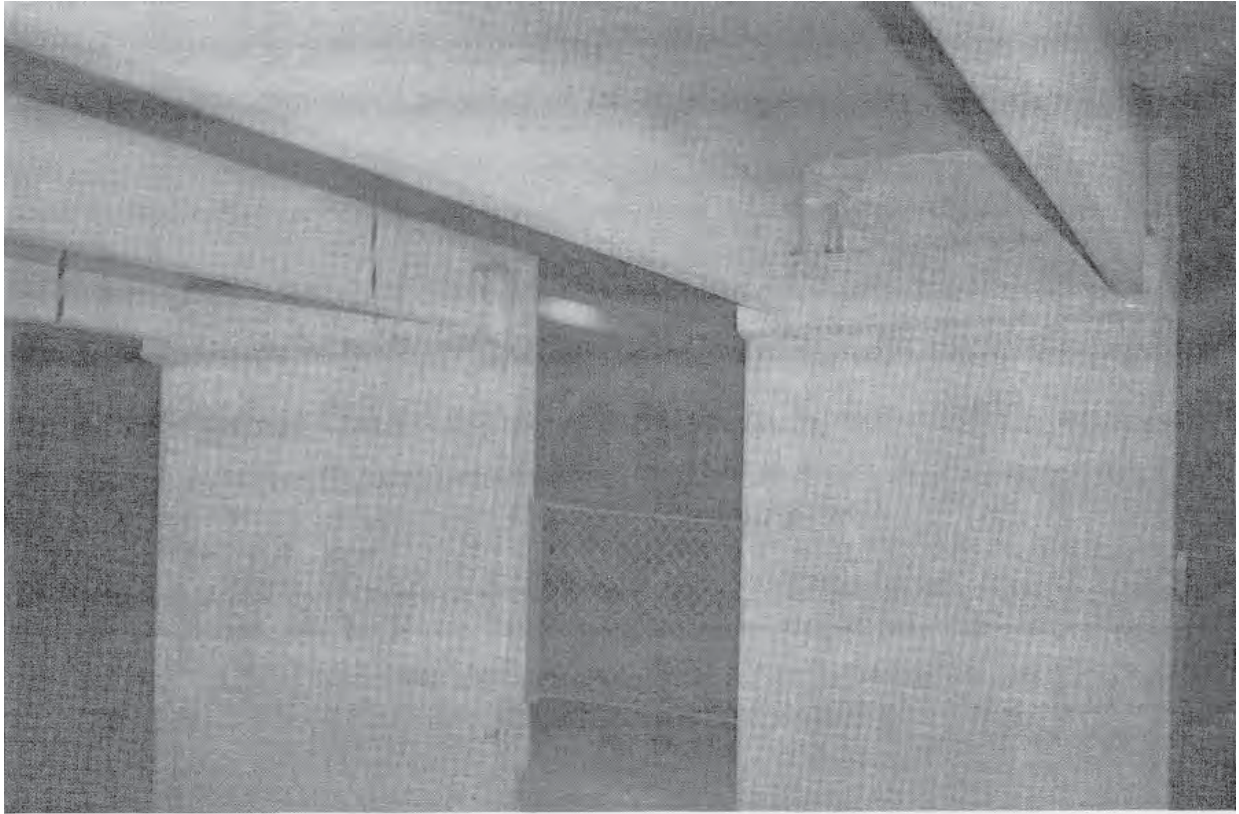

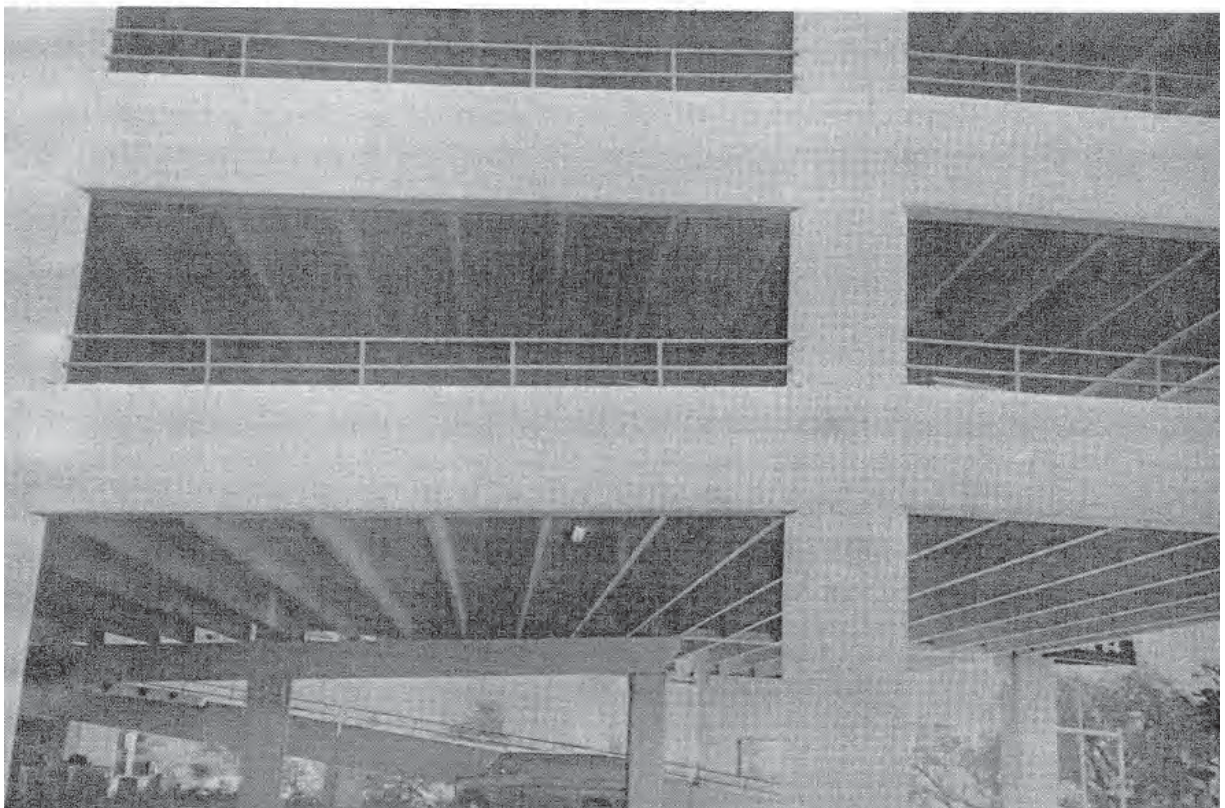
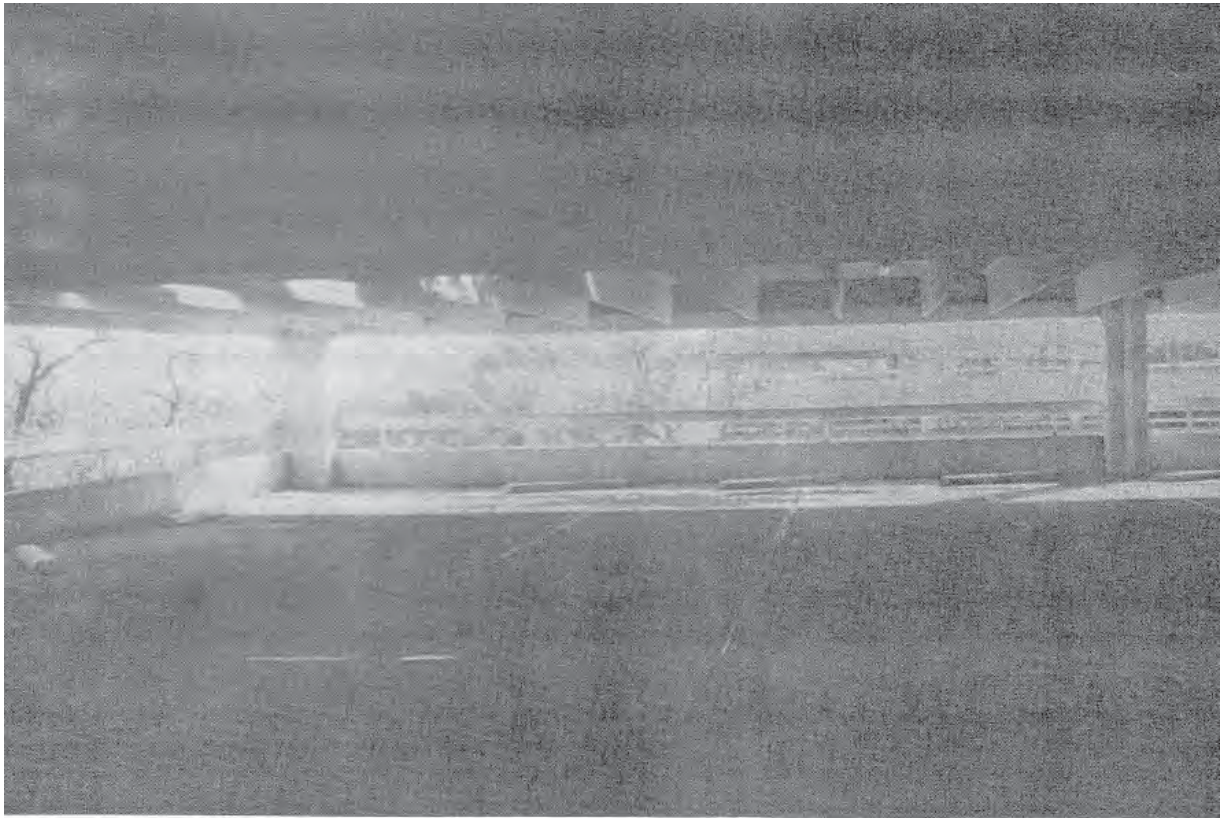

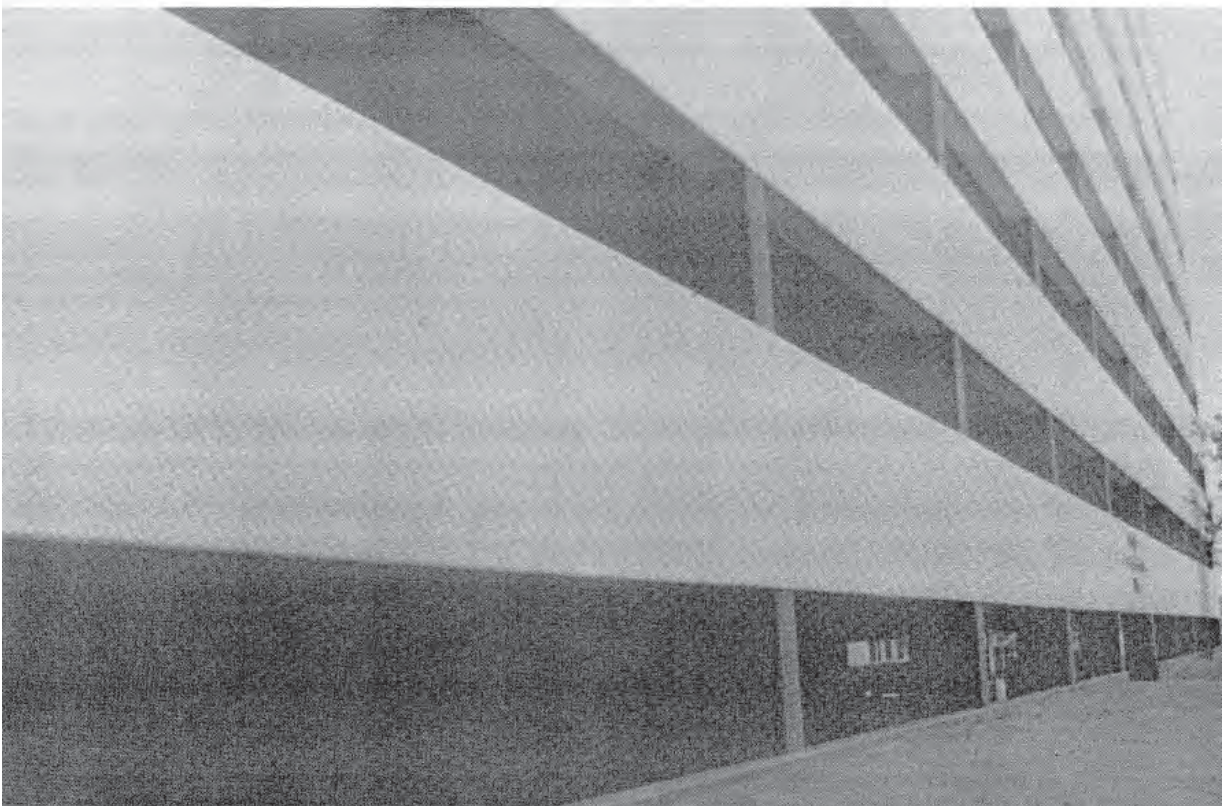
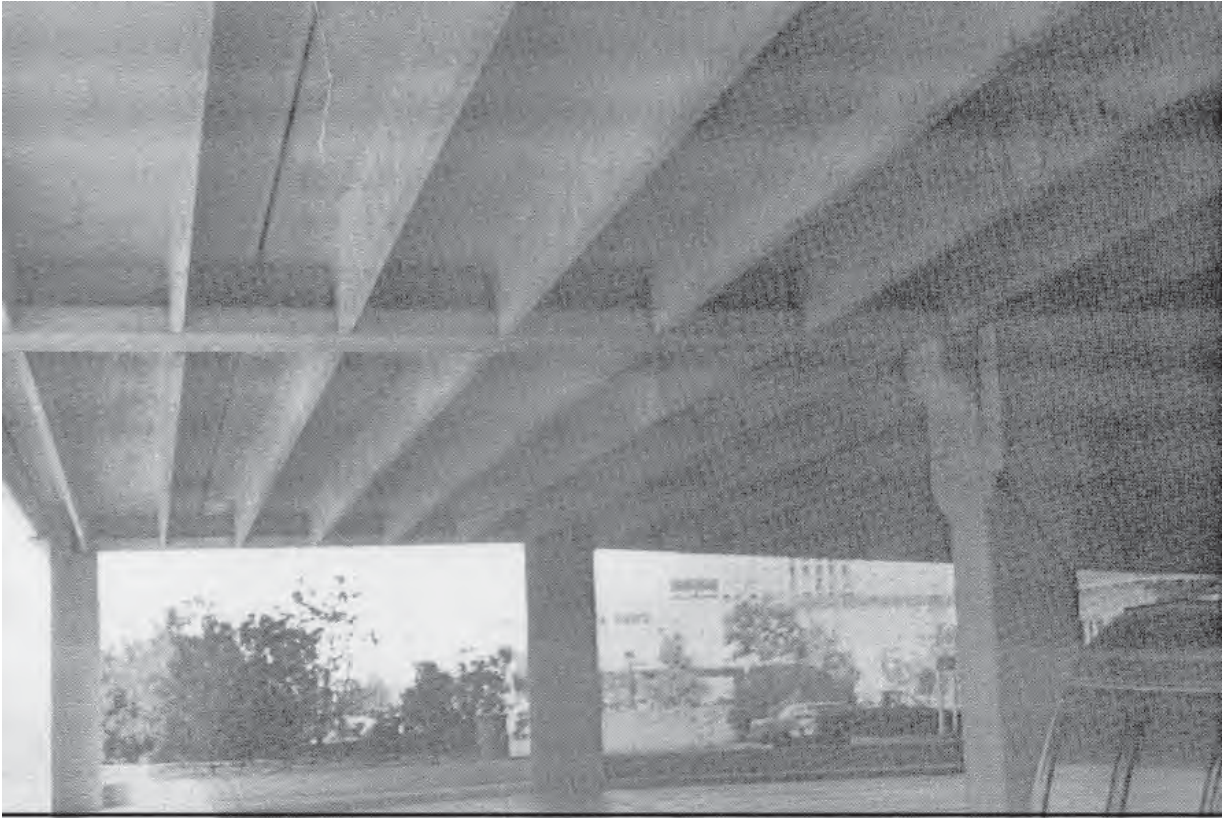

E. KEY SPECIFICATION ITEMS

1. Joints between tee flanges must be taped to contain the concrete topping. This prevents leakage which can cause voids near the flange joints. When the joints are not sealed differential curing occurs, creating cracks in the topping.
2. Control joints in the topping must be tooled directly over the joints, between tee flanges and between tee flange and beam web, when the concrete is still in its plastic state. Joints may not be sawcut after the concrete has set, because the crack pattern has already been established at that point. Use Goldblatt Groover (Model #06-314-M7) for tooling joints.
3. All topping joints must be abraded clean and filled with a top quality polyurethane sealant.
4. Topping thickness should be uniform, following the camber of the tee. Topping thickness should be 2" minimum in warm climates and 3" in harsh freeze/thaw climates.
5. All bearing conditions should have flexible neoprene bearing pads, meeting AASHTO specifications (Division II, Section 25). Plastic pads and steel shims are not recommended. Grouting precast bearing conditions eliminates needed flexibility.
6. Pads must be held back 1" from edge of support to prevent spalling caused by bearing on the edge of the support.
7. Grout in joints below columns and bearing wall panels should be non-shrink, non-metallic grout (5000 psi, minimum, at 28 days).
8. Exposed precast members, such as spandrel panels, must be designed and reinforced for crack control (in accordance with PCI and ACI 318), using a crack width limit of 0.005". Side face reinforcement must satisfy the minimum longitudinal steel required by ACI 318-10.6.7 for deep spandrel beams. Where panels are used as vehicle barriers, panels must be designed for impact loads.
9. All embedded metal assemblies exposed to rain or snow should be hot-dipped galvanized. All other embedded steel plates should be painted with epoxy paint. Welds on galvanized metal must be protected with cold galvanizing compound, applied in the field. Welds on epoxy painted metal should be touched up with epoxy paint.
10. Use 5000 psi hardrock concrete for topping, to increase durability and density. Use 5000 psi concrete, minimum, in precast members.
11. Provide 4% to 6% of air entrainment in precast concrete and 5% to 7% in topping. This greatly reduces concrete surface scaling and flaking. Admixture must conform to ASTM C 260.
12. Do not trowel the cast-in-place topping before the bleedwater evaporates. Doing so will reduce the air entrainment in the top surface, which decreases its resistance to scaling and flaking. Early troweling also drives the moisture back into the concrete, increasing the water/cement ratio. [7]
13. Use a medium broom or float swirl finish. Avoid a hard troweled finish. Ramps with slopes in excess of 10% should receive a raked finish parallel to the slope.
14. Limit water/cement ratio to 0.45 in topping (5 gallons/sack of cement). This gives a higher strength concrete with lower permeability, less shrinkage, and better durability. This mix produces less bleedwater so finishing can proceed rapidly.
15. Steam or moist cure the precast members in the plant, per ACI 318.
16. Admixtures, except air entrainment, must conform to the requirements of ASTM C 494. Admixtures containing calcium chloride are prohibited in prestressed members.
17. Due to the low slump (2" to 3") produced by limiting the water/cement ratio to 0.45 in the topping slab, specify that a properly engineered superplasticizer be added to the concrete mix to improve fluidity of the mix.

18. Water cure concrete topping slab for seven days. This greatly enhances the durability of the concrete. Alternate solutions must be equal in quality, applied immediately, and properly maintained. CURING COMPOUND MUST BE COMPATIBLE WITH SEALER.
19. Use a good quality, urethane-based penetrating sealer on all concrete parking surfaces, except the top level, to prevent water and chloride infiltration. On the top level, a silane-based penetrating sealer should be used. Also, the use of a waterproofing membrane should be considered over any occupied space, as well as the top parking level in harsh, cold climates.
20. Use a proven “T” type expansion joint cover. The “T” type expansion joint requires a blockout in the top surface, which forms a “T” with the joint. A prefabricated joint seal is set in the blockout.
21. In climates where salt is used for deicing, calcium nitrite should be added to the topping slab concrete mix at a rate of two gallons/cubic yard. This is costly and local practice should be researched before specifying its use. Do not omit its use unless convinced it is not required, or some acceptable alternative is found.
22. Microsilica (or “silica fume”), used in conjunction with a superplasticizer, produces a denser, higher strength concrete with greatly reduced permeability. It is not widely used but is gaining acceptance and should be considered.

F. DISCUSSION OF PROBLEMS AND PROPOSED SOLUTIONS

The following is a list of problems frequently encountered in garage design and construction, along with corresponding solutions to these problems. This document should be reviewed by the contractor and subcontractors. It emphasizes items which are not acceptable construction practice. These recurring problems and remedial work will reduce the life expectancy of the garage. None of the corrections are equal to the quality of the original details.

1. FABRICATION AND ERECTION TOLERANCES

Problem	Proposed Solution
a. Insufficient tee bearing due to fabrication or erection errors.	Minimum detailed bearing length must be provided. Replace member having insufficient length or realign member on supports before topping is cast. Recognize during detailing of system that minimum tolerances are hard to meet. Detail in extra flexibility to accommodate a reasonable amount of erection errors.
b. Sloped or point bearing of beams or tees.	Use tapered galvanized steel shim or bearing pads to provide uniform bearing. Tack weld steel shim to confinement plate to prevent its sliding out of place.
c. Mislocated weld plates.	Engineer must review each case individually. May require larger connection members or expansion bolted plates.
d. Unequal camber in adjacent tees.	Preloading high tee with weights or jacking and shoring lower tee are possible solutions. This must be done before welding the connections along the horizontal joint. Shimming bearing area between two neoprene pads is permissible, within specified limits. This requirement must be understood before construction begins. Replacing and repositioning members to match up camber is usually not an option due to loss of time.
e. Excessive gap between tees or between beam and tee.	Reposition tees not within specified tolerance. See previous comment.
f. Mislocated anchor bolts for precast columns.	Require surveyor to locate center line of columns. Use templates to locate bolts. A good start on erection can eliminate many tolerance problems.

- | | |
|--|---|
| g. Members cracked or damaged due to stresses induced during transportation or lifting. | Repair or replace. Submit repair procedure to Engineer for approval. Pressure injection of epoxy grout is normal repair procedure, but should only be done with Engineer's approval. This is not a magic cure for all problems. |
| h. Mislocated bearing pad extends beyond ledge. | Not acceptable. Emphasize early to erector and correct all out-of-tolerance pads before topping is cast. Bearing pads extending beyond the edge of the supporting ledge will inevitably cause spalling of the ledge. |
| i. Insufficient beam to column bearing. | Not acceptable. Recognize at placement and resolve. See item 1.a. |
| j. Excess camber causes misalignment with dowels into spandrel, parallel to span of double tees. | Detail thickened topping along spandrels, which allows more flexibility for misalignment. Shop drawings must locate inserts in spandrel above camber line of tee. |
| k. Excessively high shim stacks and rusting of steel shims. | Use prefabricated, galvanized steel shims of same size as bearing pad. Align shims and pads, alternate steel and neoprene pads. Don't use plastic shims. |
| l. Cracking and spalling due to inadequate clearance between the end of a member and an abutting vertical surface. [6] | Recognize problem during erection of member. Replace member of incorrect length. End of member may be sawn off if feasible. Do not chip. Realign supporting members. Contractor should clean out all debris and concrete in the joint. |
| m. Beam rotates when tees are set in place. | Inverted tee beams can be externally braced during erection or braced with galvanized steel angles. L-shaped beams must be permanently braced with galvanized steel angles. Avoid making the connection too rigid, which prevents lateral movement and cracks the concrete at the connection. |

2. ENVIRONMENT RELATED PROBLEMS

Problem	Proposed Solution
a. Failure to account for expansion and contraction over range of temperature experienced.	For buildings longer than 250 ft in one direction, consider adding pour strips. For buildings longer than 300 ft, provide expansion joints. Design expansion joint for movement caused by a 100 degree variation in temperature (minimum) or higher if local conditions dictate. The top deck is subjected to direct sunlight and/or ice and should be designed for an additional 30 degrees variation. This extra temperature movement in top deck will add stress to the top column tier.
b. Expansion joint structural design.	The anchorage details should be designed to transmit the forces induced. It is desirable to provide a vertical load transfer connection across the joint (intended to equalize vertical deflection under rolling loads) while permitting lateral expansion/contraction movement.
c. Expansion joint inoperative or leaking.	Use "T" type expansion joint. Locate joint at high point of drainage system and build up topping at expansion joint to direct water away from joint. Keep joint clean and free to move.

- d. Improper connection detailing between restraining elements (walls and columns) and floor systems, causing cracking in the restraining elements. Avoid locating the restraining elements (such as stairs and elevator towers) at ends of the structure, to prevent excessive stress build-up due to thermal effects, creep, and shrinkage. Design and detail connection for the forces which will develop.
- e. Concrete has a relatively low tensile capacity and will crack due to shrinkage during the curing phase. **1)** Provide tooled control joints at junction of tee flanges and at junction of IT and tee **2)** Use low water/cement ratio, low slump and higher strength topping mix with 3/4" aggregate **3)** Provide proper curing using wet burlap for 7 days or by using properly applied and maintained curing compound **4)** Consider shrinkage compensating (Type K) cement **5)** Wet down precast surfaces before pouring topping and **6)** Grind out and seal cracks that occur outside of the normally tooled control joints.
- f. Concrete cracks under imposed loads or thermal forces. Cracks may be anticipated but cannot be prevented altogether. Reinforce areas subject to cracking to reduce width of cracks and provide safe load transfer.
- g. Cracking increases due to the creep of concrete under sustained load and due to cyclic loading and unloading of the garage. Maintain the sealer or waterproofing membrane on top deck to protect cracks from moisture intrusion.
- h. Corrosion of reinforcement is caused when water enters through cracks and reaches the reinforcing steel. Corrosion causes loss of steel area which means loss of strength. Steel expands as it corrodes causing spalling of the concrete that encloses it. **1)** Provide adequate clear cover over reinforcing. Code minimums may need increasing for a good serviceable condition. Architectural reveals in spandrels may dictate reinforcing location. Provide 1 1/2" cover over all top steel in prestressed members and 2" or 2 1/2 bar diameters in non-prestressed elements. Use flat sheets of welded wire mesh or bars (do not allow rolls) supported on plastic chairs **2)** Where deicing salt is used, use non-corroding reinforcing in all non-prestressed concrete, within the top 2 1/2" of the element or slab. Epoxy coated rebar, fiber mesh reinforcing, and galvanized rebar can be used. **3)** Apply a penetrating sealer to all slabs. Use silane-based sealer on areas exposed to direct rain and sunlight. In harsh climates where freeze/thaw environment exists, consider applying a waterproofing membrane to the top deck **4)** Tool joints in topping at points of anticipated cracking and seal joints **5)** Seal joints where cast-in-place concrete topping is cast against walls, spandrel beams, etc. **6)** Slope cast-in-place topping away from walls, spandrel beams, expansion joints, etc., to direct water away from joints **7)** Provide an adequate number of and sufficient slope to drains. Parking deck should be pitched for drainage a minimum of 1/8" per foot and, **8)** Where salt is used for deicing, calcium nitrite should be added to the concrete mix for the topping slab. Use approximately 2 gallons/cubic yard. This is expensive and local practice should be researched before specifying. However, do not omit unless convinced it is not required, or unless some alternate admixture is specified.

3. CONSTRUCTION RELATED PROBLEMS

Problem	Proposed Solution
a. Mislocated anchor bolts.	See item 1.f.
b. Inadequate air entrainment.	Conform to Specifications: 5% ± for precast; 6% ± for cast-in-place.
c. Troweling before bleedwater evaporates, reducing air entrained in top surface and driving out moisture needed for hydration.	Contractor to monitor.
d. Placing topping prior to correction of all bearing problems.	Contractor and testing laboratory should inspect and accept all bearing conditions prior to topping pour.
e. Sawcutting control joint in lieu of tooling joint.	Allow only tooled joint. See "Quality Control," Chapter 11, for reasons sawcutting is not allowed.
f. Insufficient construction bracing.	Precaster must prepare erection plans for contractor and erector's use.
g. Failure to grout base plate after column or wall is plumbed. Placing floors above may cause local failure.	Contractor and testing laboratory must monitor.
h. Improper placement of bearing pads.	See item 1.h.
i. Failure to cold galvanize welded connections.	Contractor and testing laboratory monitor.
j. Scheduling: Pieces damaged in transit or erection may have to be recast which causes delays or redirection of erection.	Contractor/Architect review individual cases. Contractor submit repair to Architect/Engineer for approval. Patches often lead to premature deterioration. Sealed cracks should not be accepted without a thorough review of the long term effects.
k. Concrete cracks where embeds are welded together.	Caused by expansion of embed due to welding heat. Use intermittent welds or cool plate during welding.
l. Tooling control joints in topping not completed before concrete hardens.	Contractor must properly plan for this item to be accomplished. This may require more finishers, temporary lighting, or smaller pours.
m. Electrical conduit corrodes resulting in concrete spalls.	Use galvanized conduit and same cover requirements as used for reinforcing steel.

4. DESIGN RELATED PROBLEMS

Problem	Proposed Solution
a. Competitive precast bid: Precasters want to bid project using their standard formwork (column size, haunch size, I.T. width, tee depth) and details. These generally do not conform exactly to drawings and specifications, making bid comparison difficult and creating a period of negotiation after precaster has been chosen. In the negotiation phase discrepancies are resolved, but often lesser solutions are accepted by the owner because the precaster offers economic incentives to use his standard system.	Drawings should state that base bid conform exactly to the drawings and specifications. Deviations from details and specifications, as proposed by the contractor, should be itemized and submitted as deduct alternates. The economic benefits can then be compared to reduction in long term quality.
b. Division of design: Precaster typically designs major prestressed members (tees, I.T.'s, and L beams). There's a cost incentive to design members as close as possible to minimum code allowables. However, there are cases where engineering judgement should dictate an alternate or an increase over code minimum design.	Engineer-of-record should identify any areas of concern and provide design, or limitation of design, on contract documents. Examples: Design of corbels, maximum allowed tensile stress in pretensioned members, areas to be designed for increased loads, and detailing 8" minimum beam ledge widths to ensure adequate tee bearing.
c. Insufficient bearing due to a member being skewed in plan.	Detail extra bearing length. The end of the member will need to be cast with a skew to maximize bearing length.
d. Spalling and cracking of beam ledge due to a bearing point too close to the end of the ledge.	Layout tees so as to avoid a stem near the end of the ledge. Reinforce ledge based on a smaller effective width. Detail continuous ledge reinforcing to be developed at the end.
e. Spalling and cracking of beam ledge at the column corbel.	Detail ledge so it does not bear directly on column corbel. Terminate ledge at edge of corbel or locate pad under web of beam only.
f. Torsional cracks in spandrel beams.	Design for eccentric loads on ledges, loads placed inside the critical section, and reduction of member depth at dapped ends.
g. Concrete cracks at embedded metals where members are welded together.	Avoid welding precast members together when possible. If welding must be done use an angle connector and reinforce around embeds.

5. MAINTENANCE RELATED PROBLEMS

Problem	Proposed Solution
a. Failure to: 1) Replace sealer on slab and sealant in joints 2) Keep drain lines clean 3) Repair leaks 4) Clean expansion joints 5) Clean and paint rusting embed plates 6) Report and repair cracked members 7) Clean and repair spalls, and 8) Identify and repair areas which pond water.	Establish and maintain regularly scheduled maintenance. All items 1 through 8 should be included on a checklist. See Section G - "Maintenance Requirements."
b. Premature failure of sealers, sealants, or waterproofing due to being installed incorrectly or in insufficient amounts.	Avoid by having a technical representative of the supplier at the jobsite to observe and affirm (in writing) that the product was used correctly. [5]

G. MAINTENANCE REQUIREMENTS

The most important factor in extending the life of a parking structure is a regular maintenance program. Maintenance programs should include the following items:

Waterproofing: Nearly all of the following systems have finite life spans. The elastomeric materials used for joint sealants and expansion joints commonly carry a manufacturer's warranty of three years but have a life expectancy of five to 20 years. Materials in areas exposed to direct sunlight will often have a shorter life span than those in protected areas.

- a. Expansion Joints in Floors: "T" type expansion joints have a traffic plate which needs to be inspected when the cover material is being replaced. These plates normally last longer than the cover material, unless leaks were not repaired soon after they occurred. Replacing these plates increases the cost of repair by 25%.
- b. Sealant at Construction Joints and Control Joints: The greatest expense of replacing polyurethane joint sealant is removing the old sealant from the joint. Replacement cost can be up to 2 1/2 times the original cost.
- c. Membrane Waterproofing System Over Occupied Space and on Top Level in Harsh, Cold Climates: Waterproofing membrane replacement cost is twice that of original installation because of labor required to remove the old coating. Be sure surface is clean and concrete repairs are made properly and not just superficially.
- d. Silane-based Penetrating Sealer on Top Level and Urethane-based Penetrating Sealer on Other Levels: Penetrating sealer is easier to replace. No preparation is required unless the surface is extremely dirty, in which case water or shot blast cleaning may be required. In cold climates, all slabs should be resealed every two to three years.
- e. It is recommended that all areas of the parking garage be inspected for water leakage at least semiannually. Where leaks occur waterproofing should be repaired or replaced as soon as practical. Spot repairs are usually more economical until about 30% to 50% of the element needs repair, at which time total replacement should be considered. [3]

Drains: Drains should be checked after heavy rains for leaks and clogging. A clogged drain can create ponding on the deck, leading to slab deterioration.

Embedded Plates: Any steel that shows signs of corrosion should be cleaned and painted. Corrosion can cause rust streaks on the concrete below, as well as lead to possible structural damage if not attended to.

Cracks: Water entering through cracks can corrode the reinforcing. Corrosion of reinforcing causes concrete expansion, resulting in spalling and loss of reinforcing strength. Cracks should be filled with epoxy or sealant to seal out water as soon as possible.

Surface Patches: Sawcut 1/2" to 3/4" deep around the damaged concrete area. Chip out, clean, and fill with high-strength, non-shrink patching mortar.

Ponding: Pondered water causes rapid deterioration of waterproofing material and then penetrate the concrete, with the same results as described for cracks. Ponding is usually caused by faulty drains, topping irregularities, or poor design. The specifications should call for deck drainage to be tested for ponding by the contractor before he leaves the project. The Architect/Engineer can recommend solutions for problem areas.

Cleaning: Cleaning should include a regular sweeping (preferably once a month) and a wash down once or twice a year. [6] As a minimum, decks in cold climates must be washed down every spring.

Inspection: Garages should be inspected every year. Regular inspection for the above items can detect problems before they become too serious or more costly to correct.

H. COST ESTIMATE

Construction Estimate: The construction quantities tabulated below are based on 1/4 of the total area of a typical floor of the garage illustrated earlier in this Chapter. These quantities could be used for comparative cost of structural construction and waterproofing. Other items such as plumbing, lighting, striping, stairs, foundations, elevators, etc., would be similar in cost for all six systems and therefore are not included. General conditions, overhead, and profit have also been excluded. For purposes of estimating sealer cost, a five level garage was assumed.

DESCRIPTION	QUANTITY	UNIT
10 DT 28 TEES	14,335	S.F.
P/C SPANDREL	167	L.F.
P/C PANEL	88	L.F.
P/C I.T. BEAM	43	L.F.
P/C WALL PANEL	760	S.F.
P/C COLUMN (24"x24")	110	L.F.
2 1/2" TOPPING SLAB	14,335	S.F.
SEALANT	1,915	L.F.
SEALER 14,335 X 4 LVLS. = 5 LVLS.	11,468	S.F.
(URETHANE-BASED @ LVLS. 1-4)		
SEALER 14,335 X 1 LVL. = 5 LVLS.	2,867	S.F.
(SILANE-BASED AT TOP LEVEL ONLY)		
AREA ESTIMATED		14,500 S.F.

DATUM ENGINEERS, INC.

Maintenance Estimate: Maintenance quantities tabulated below are based on 1/4 of the total area of a typical floor of the garage illustrated earlier in this Chapter. These quantities could be used for comparative cost of maintenance items related to this particular system. Other items such as sweeping, wash downs, drain cleaning, restriping, etc., would be similar in cost for all six systems and therefore are not included.

DESCRIPTION	QUANTITY	UNIT
REPLACE SEALANT	1,915	L.F.
REPLACE SEALER (LVLS. 1-4)	11,468	S.F.
REPLACE SEALER (TOP LEVEL ONLY)	2,867	S.F.
AREA ESTIMATED		14,500 S.F.



Untopped Precast Concrete 4

CHAPTER 4

UNTOPPED PRECAST CONCRETE

A. DESCRIPTION

Precast concrete columns, beams, and double tees without cast-in-place concrete topping. Precast tee becomes the parking surface. According to a recent survey on precast garages, some of the best performing decks in cold climates have been untopped. [6]

B. ADVANTAGES

Economical - Most concrete casting is done at the precast plant under controlled conditions. There is little forming, reinforcing, or concrete casting in the field once the foundation is constructed. Although the cost of the tees is higher, the cost of the cast-in-place topping is eliminated.

Rapid Construction - Members are prefabricated in the precast plant at the same time that the foundation is being constructed. Erection is normally very rapid. This is especially desirable when existing surface parking or traffic is being interrupted to make way for a new garage.

All-Weather Construction - Adverse weather does not hinder erection or fabrication as much as with cast-in-place construction. Some precast plants in colder regions are enclosed, so precasting is not interrupted.

Eliminates Formwork - Formwork in the field is essentially eliminated. The tee becomes the permanent parking surface and cast-in-place concrete topping is not required.

Proper Tendon Placement - Plant fabrication provides more accurate tendon placement and stressing than can be accomplished in the field with post-tensioning. Bonded strands are protected indefinitely by the concrete cast against them, whereas unbonded tendons used in post-tensioning are susceptible to corrosion if water and salt enter the sheathing.

Proper Curing - Concrete cast in the fabrication plant can be properly steam cured, which results in better quality concrete than that cast in the field. Steam curing is much more effective than other types of curing.

Good Wearing Surface - Top of the precast tee is the wearing surface. It is normally cast with higher strength concrete (5000 to 6000 psi) than a cast-in-place slab (3000 to 4000 psi). This results in a more durable surface.

Minimal Cracking - Shrinkage and thermal stress cracks do not occur in the exposed surface. The full-depth joints between each tee provide crack free movement due to temperature changes. Plant casting affords controlled curing conditions, as opposed to curing and protecting a large thin slab area exposed to direct sunlight at the jobsite.

Concrete Quality - There is a better chance of maintaining consistent concrete quality in a precast plant than can be obtained in the field. Water/cement ratio, air quantity, and reinforcing cover are better controlled.

Thicker Flanges - Flanges on tees are 4" to 5" thick, as opposed to 2" or 2 1/2" on topped tees. This eliminates the unsightly flange cracks which commonly occur during removal of forms, shipping, handling, and erection.

Repairable Leaks - Due to the thick flanges constructed of high strength concrete, under controlled curing procedures in the plant, cracks (and therefore leaks) seldom occur in the concrete. The majority of the leaks occur in the joints which are easily located and waterproofed.

Exterior Appearance - Exterior architectural finishes are more consistent. Plant fabrication provides for easier and more consistent forming and better quality control than is possible in the field.

C. DISADVANTAGES

Tee Camber - Adjacent double tees must have matching camber so they can abut each other without creating bumps in the drive lanes. This can be accomplished by using deeper members and keeping prestressing stresses low and by arranging units for more consistent camber.

Joints - All edges of tees must be sealed with a high quality, flexible joint sealant. Sealant must attach to tees and not fall through joints. This requires proper edge finishing, joint detailing, and excellent casting tolerances. Sealant must withstand heat, cold, vibration, and automobile traffic.

Interior Appearance - Parking surface will not have the smooth uniform appearance that cast-in-place decks have.

Shear Connectors - Shear connectors must be designed for both traffic and diaphragm loads. Connectors must be hot-dip galvanized and protected from moisture to prevent corrosion.

Connections - Connections must be oversized for erection tolerances. They must be recessed and the metal must be hot-dip galvanized. Field welding destroys the galvanizing. These welds must be touched-up with cold galvanizing compound. They must be designed to provide the bracing which is normally accomplished by doweling into the topping. Connections not detailed with enough flexibility will crack the concrete. Extra reinforcing must be provided at rigid connections to keep the cracks from opening up.

Erection Problems - problems that arise during erection due to out-of-tolerance fabrication and poor erection practices. These include member misplacement, rotation of members on pads, point bearing, loss of bearing, edges spalling, etc.

Less Adaptable - Precast construction allows less flexibility than cast-in-place systems for complex shapes, irregular sites, and curved ramps. It is difficult to create the necessary slope to drains since no topping is used and the 4" flanges usually cannot be warped.

Maintenance - Joint sealant must be replaced if damaged or removed. Otherwise leaks will occur.

Heavier Weight - Because untopped tees are usually made of hardrock concrete and have thicker flanges, they will weigh about 80-85% more than a standard tee. This may affect the cost of transportation and crane erection.

Lighting - Due to the closely spaced stems, lighting is not easily or efficiently accomplished. Lights normally have to be placed between tee stems, and not below, due to headroom considerations.

D. RECOMMENDED DETAILS

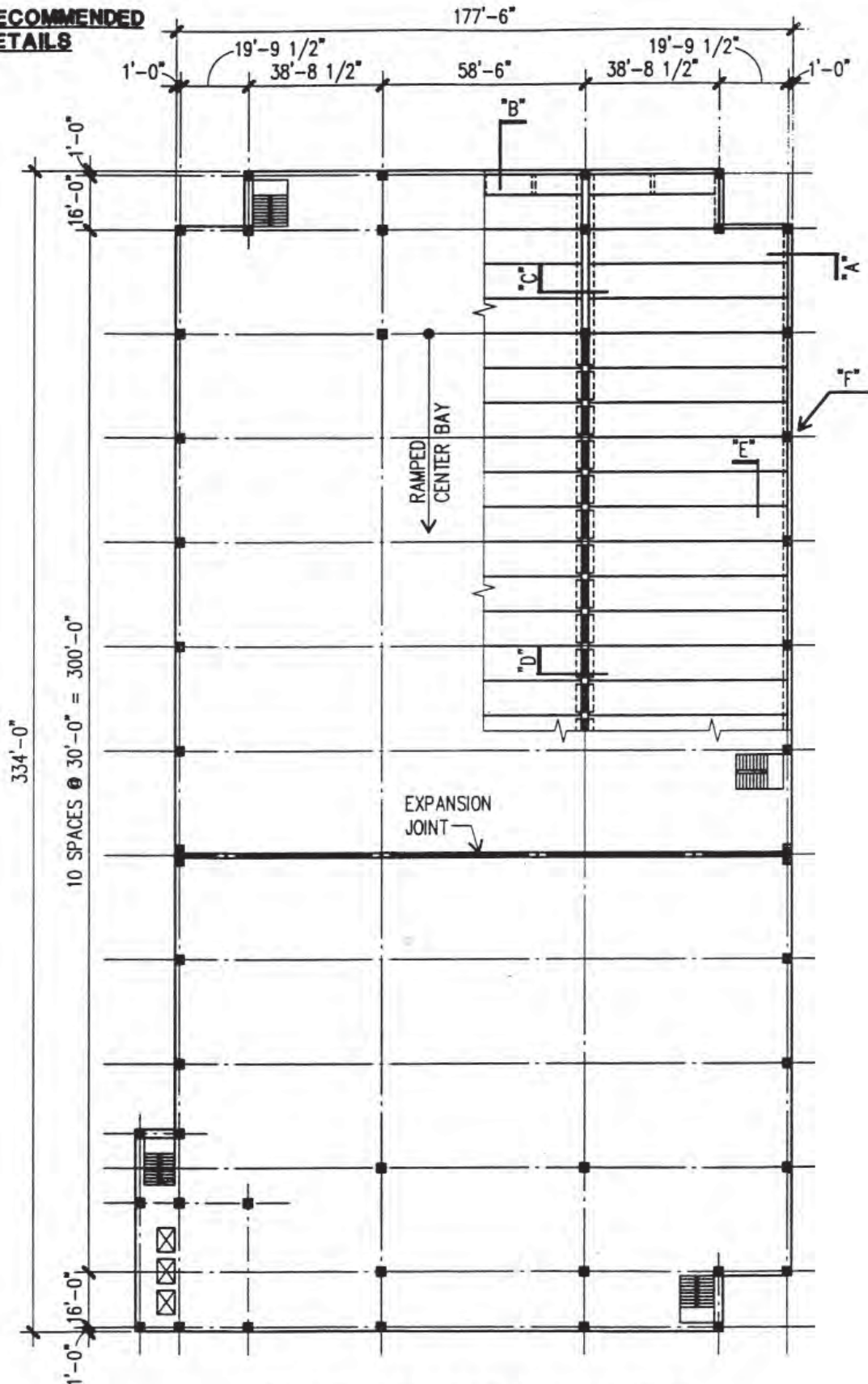

TYPICAL FLOOR FRAMING PLAN
1"=40'-0"

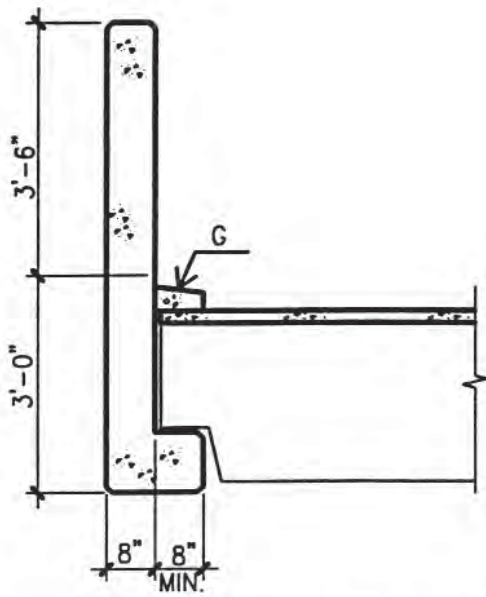

A TYPICAL SPANDREL BEAMS
 $3/8" = 1'-0" \text{ TYP.}$

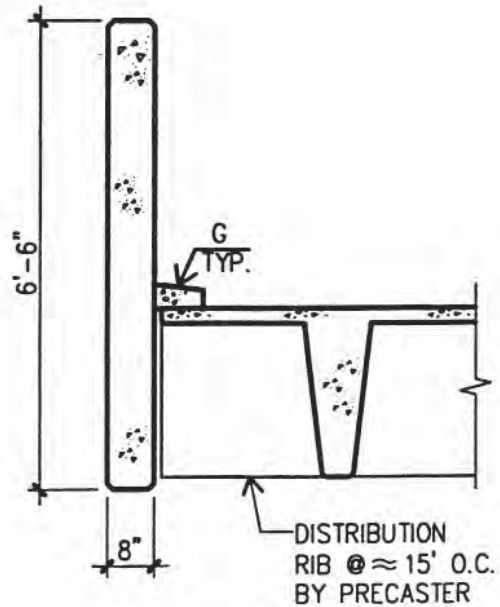

B

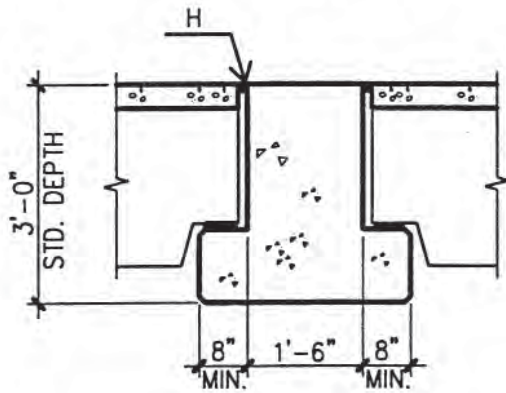

C TYPICAL PRESTRESSED INVERTED TEE BEAM

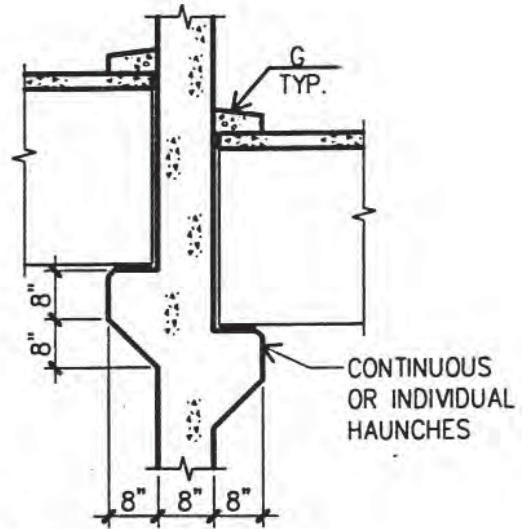

D TYPICAL INTERIOR WALL PANEL

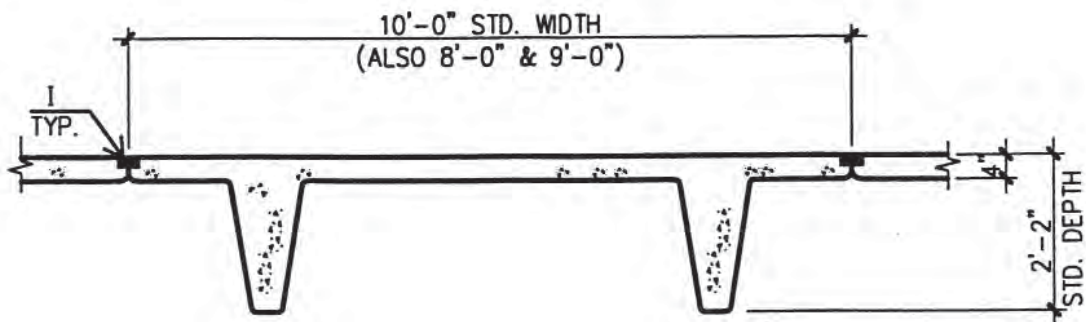

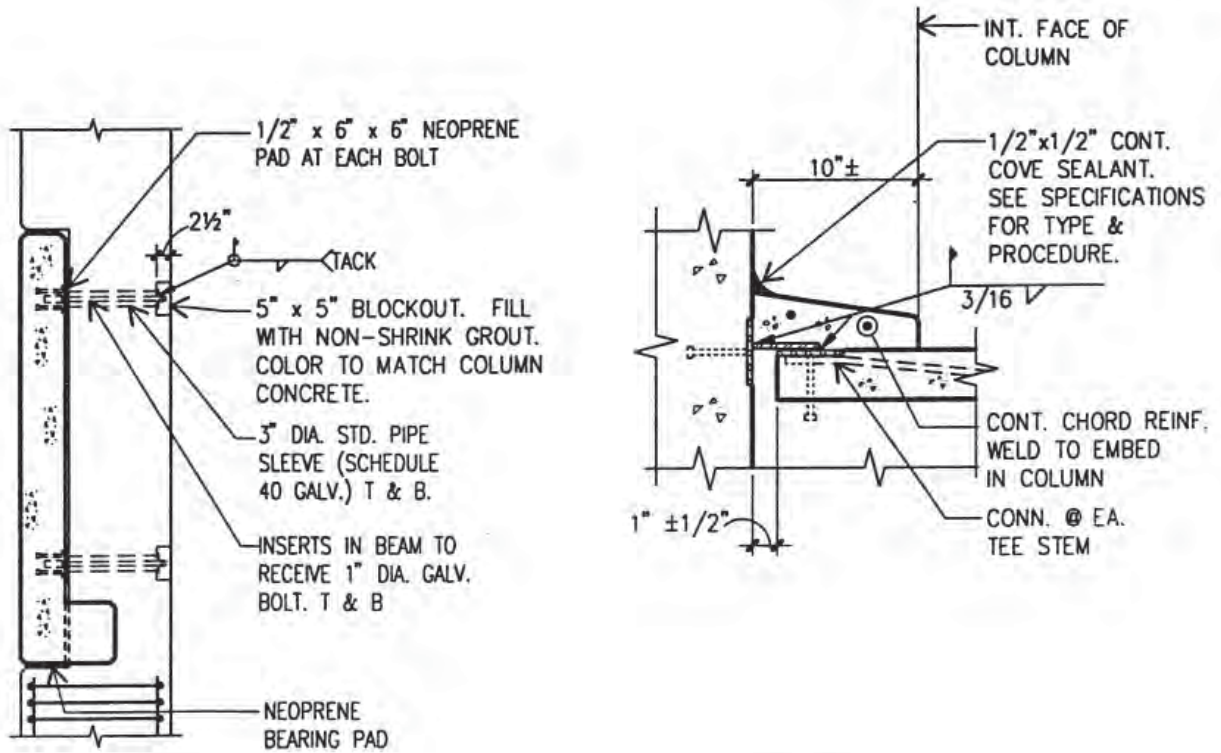

F

G

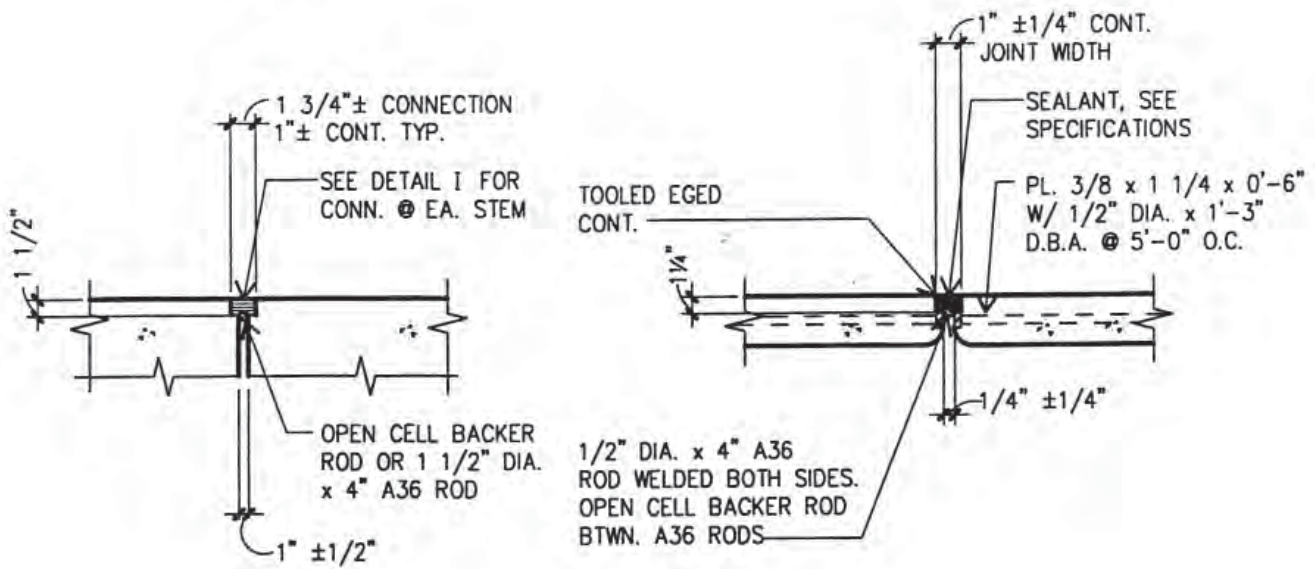

H

I

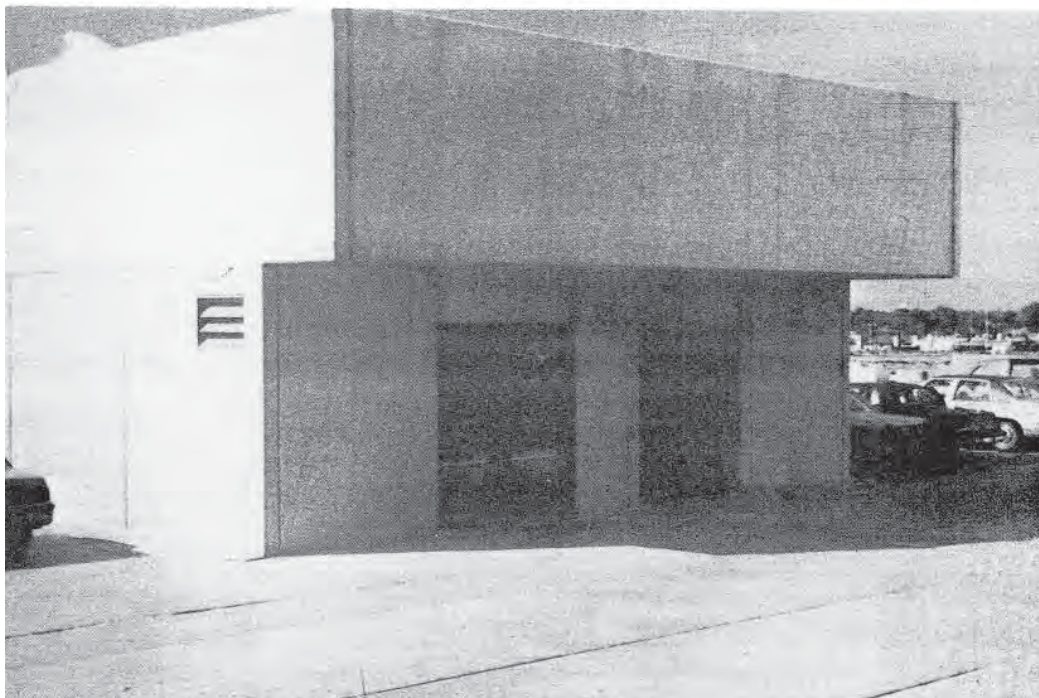
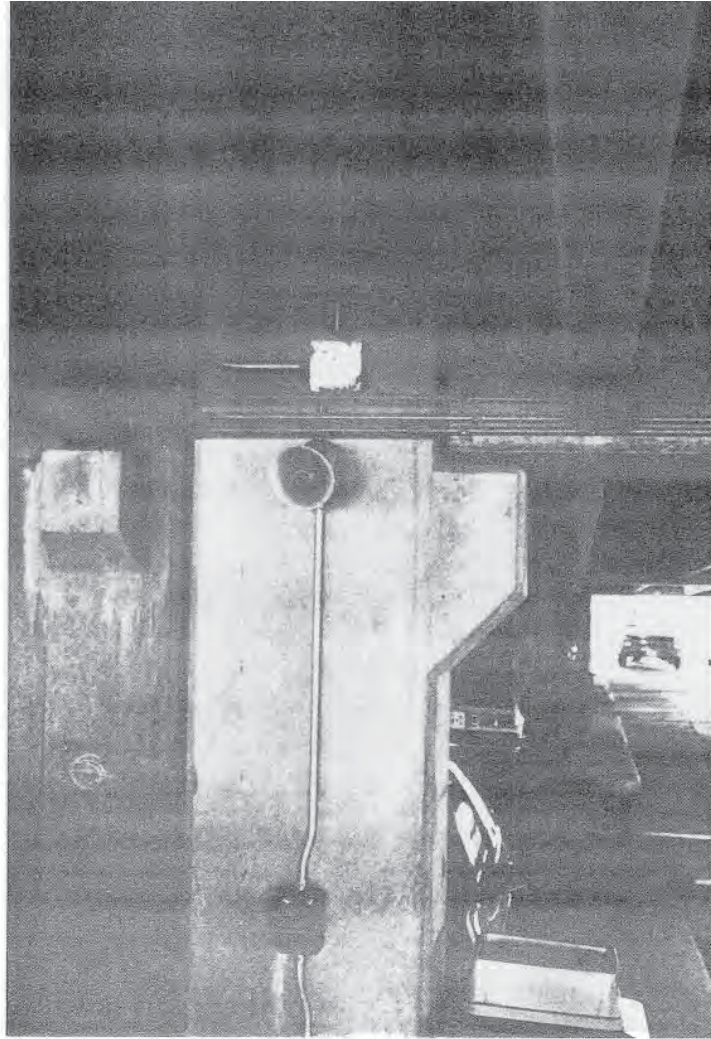

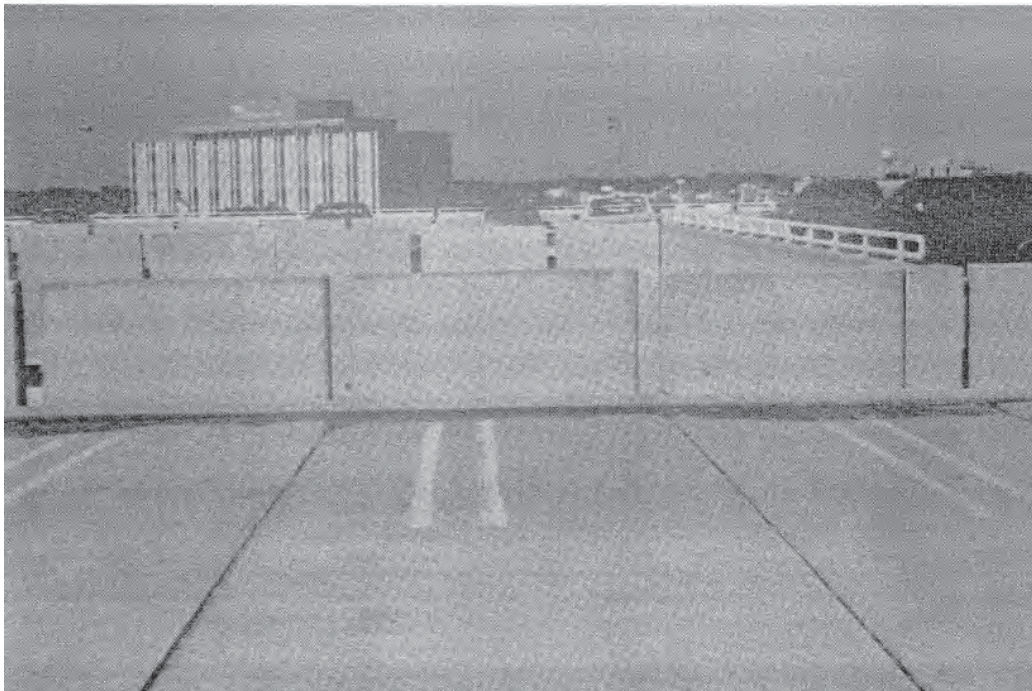

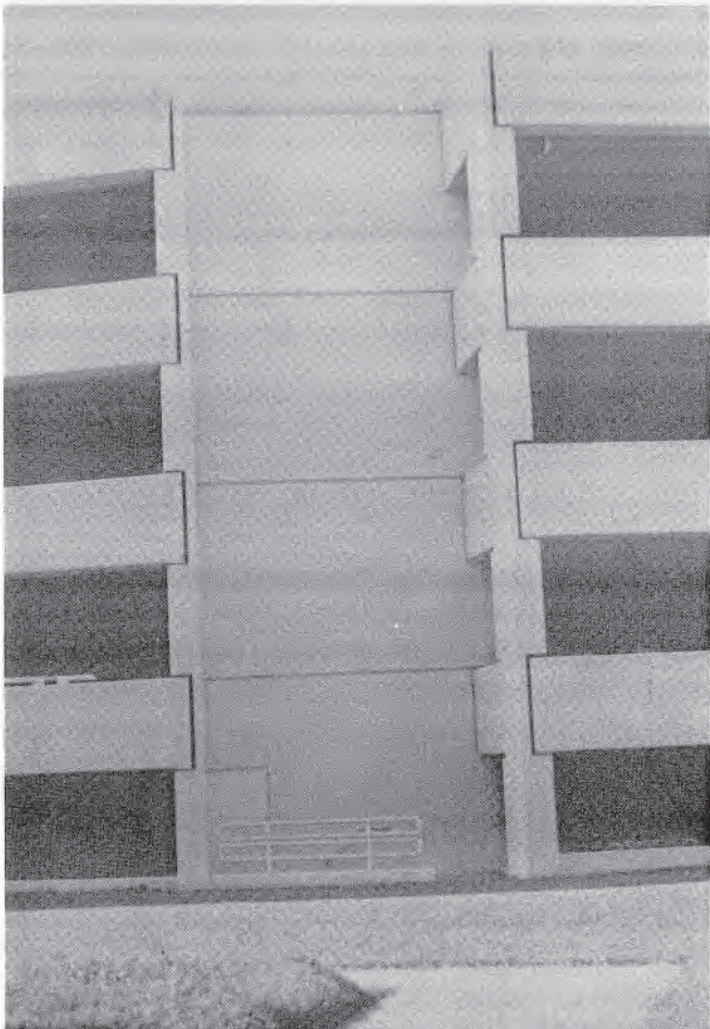
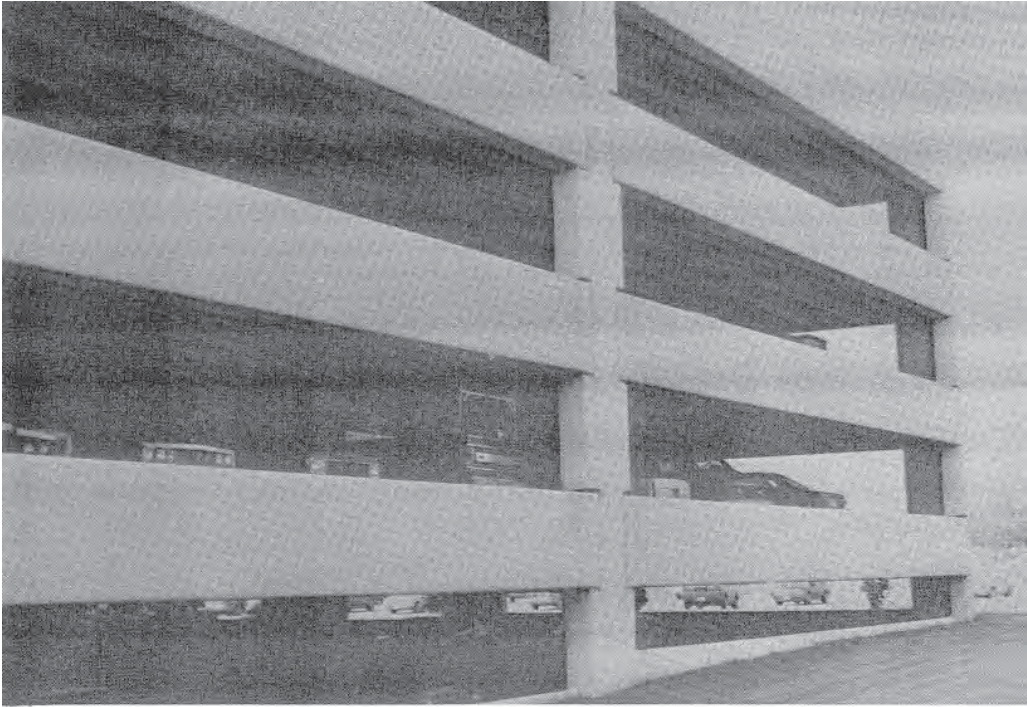

E. KEY SPECIFICATION ITEMS

1. Fabrication and erection tolerances are critical since all joints are exposed and sealed.
2. Joints must be cleaned and then sealed with a top quality polyurethane sealant.
3. Bearing conditions should meet AASHTO specifications (Division II, Section 25). Plastic pads and steel shims are not recommended. Grouting precast bearing conditions destroys needed flexibility.
4. Pads must be held back 1" from edge of support to prevent bearing on the edge, causing it to spall.
5. Grout in joints below columns and bearing wall panels to be non-shrink, non-metallic grout (5000 psi minimum, at 28 days).
6. Exposed precast members, such as spandrel panels, must be designed and reinforced for crack control (in accordance with PCI and ACI 318), using a crack width limit of 0.005". Side face reinforcement must satisfy the minimum longitudinal steel required by ACI 318-10.6.7 for deep spandrel beams.
7. All embedded metal assemblies to be hot-dip galvanized. Welds on galvanized metal must be protected with cold galvanizing compound, applied in the field.
8. Top surfaces of double tees shall receive a medium broom finish for grades of 10% or less and raked finish for more than 10%, such as ramp areas.
9. Provide 4% to 6% air entrainment in precast. Admixture must conform to ASTM C 260.
10. Use a 5000 psi hardrock concrete, minimum.
11. Use a maximum water/cement ration of 0.45 (5 gallons/sack of cement). This provides a higher strength concrete with lower permeability, less shrinkage, and better durability.
12. Steam or moist cure the precast tees in the plant, per ACI 318.
13. Use a quality urethane-based penetrating sealer on all concrete parking surfaces, except the top level, to prevent water and chloride infiltration. On top level, a silane-based penetrating sealer should be used. The use of a waterproofing membrane should be considered over any occupied space.
14. Use a proven "T" type expansion joint cover.
15. Admixtures, except air entrainment, must conform to requirements of ASTM C 494. Admixtures containing calcium chloride must not be permitted in prestressed concrete.
16. Due to the low 2" to 3" slump (produced by low water/cement ratio), specify that a properly engineered superplasticizer be added to the mix to improve fluidity.
17. In harsh cold climates where salt is used for deicing, add to the concrete mix 2 gallons of calcium nitrate/cubic yard. This is expensive and a reasonable alternative may be found, but conform to local practice as a minimum solution.
18. Microsilica (or "silica fume"), when used in conjunction with a superplasticizer will produce a denser, higher strength concrete with greatly reduced permeability. It is not widely used but is gaining acceptance and should be considered.

F. DISCUSSION OF PROBLEMS AND PROPOSED SOLUTIONS

The following is a list of problems frequently encountered in garage design and construction, along with corresponding solutions to these problems. This document should be reviewed by the contractor and subcontractors. It emphasizes items which are not acceptable construction practices. These recurring problems and remedial work will reduce the life expectancy of the garage. None of the corrections are equal to the quality of the original details:

1. FABRICATION AND ERECTION TOLERANCES

Problem	Proposed Solution
a. Insufficient tee bearing due to fabrication or erection errors.	Minimum detailed bearing length must be provided. Replace member having insufficient length or realign member on supports before topping is cast. Recognize during detailing of system that minimum tolerances are hard to meet. Detail in extra flexibility to accommodate a reasonable amount of erection errors.
b. Sloped or point bearing of beams or tees.	Use tapered galvanized steel shim or bearing pads to provide uniform bearing. Tack weld steel shim to confinement plate to prevent its sliding out of place.
c. Mislocated weld plates.	Engineer must review each case individually. May require larger connection members or expansion bolted plates.
d. Unequal camber in adjacent tees.	Preloading high tee with weights or jacking and shoring lower tee are possible solutions. This must be done before welding the connections along the horizontal joint. Shimming bearing area between two neoprene pads is permissible, within specified limits. This requirement must be understood before construction begins. Replacing and repositioning members to match up camber is usually not an option due to loss of time.
e. Excessive gap between tees or between beam and tee.	Reposition tees not within specified tolerance. See previous comment.
f. Mislocated anchor bolts for precast columns.	A good start on erection can eliminate many tolerance problems. Require a surveyor to locate center line of columns. Use templates to locate bolts.
g. Cracked or damaged members due to stresses induced during transportation or lifting.	Repair or replace. Submit repair procedure for Engineer's approval. Pressure injection of epoxy grout is normal repair procedure but should only be done with Engineer's approval. This is not a magic cure for all problems.
h. Mislocated bearing pad extends beyond ledge.	Not acceptable. Emphasize early to erector and correct all out-of-tolerance pads before welds are made. Bearing pads extending beyond the edge of the supporting ledge will inevitably cause spalling of the ledge.
i. Insufficient beam to column bearing.	Not acceptable. Recognize at placement and resolve. See item 1.a.
j. Excessively high shim stacks and rusting of steel shims.	Use prefabricated, galvanized steel shims same size as bearing pad. Align shims and pads. Alternate steel with neoprene pads. Do not use plastic shims.

- k. Cracking and spalling due to inadequate clearance between the end of a member and an abutting vertical surface. [6] Recognize problem during erection of member. Replace member of incorrect length. End of member may be sawn off if feasible. Do not chip. Realign supporting members. Contractor to clean out all debris and concrete in the joint.
- l. Beam rotates when tees are set in place. Inverted tee beams can be externally braced during erection or braced with galvanized steel angles. L-shaped beams must be permanently braced with galvanized steel angles. Avoid making connection too rigid; this prevents lateral movement and cracks the concrete at the connection.

2. ENVIRONMENT RELATED PROBLEMS

Problem	Proposed Solution
a. Failure to account for expansion and contraction over range of temperature experienced.	Locate expansion joints at 250 feet maximum. Design expansion joint for movement caused by a 100 degree variation in temperature, minimum, or higher if local conditions dictate. Note that the top deck is subjected to direct sunlight and/or ice and should be designed for an additional 30 degrees variation. This difference between top deck and the deck below also increases stresses in the columns.
b. Expansion joint inoperative or leaking.	Use "T" type expansion joint. Shim up stems of the tee on each side of expansion joint, to create a slope to direct water away from the joint. Keep joint clean and free to move. Anchorage detail should be designed to transmit the forces induced. Shear force should be transferred across the joint as wheel loads approach. It is desirable to provide a vertical force transfer connection across the joint intended to equalize vertical deflection while permitting the intended expansion/contraction movement.
c. Improper connection detailing between restraining elements (walls and columns) and floor systems, causing cracking of restraining elements.	Avoid locating the restraining elements at ends of the structure to prevent excessive stress building up due to thermal effects, creep, and shrinkage. Design and detail connections for the forces which will develop.
d. Corrosion of reinforcement is caused when water enters through cracks and reaches the reinforcing steel. Corrosion causes loss of steel area which means loss of strength. The steel expands as it corrodes and causes spalling of the concrete which encloses it.	1) Provide adequate clear cover over reinforcing. THIS MAY BE THE MOST IMPORTANT PRINCIPLE TO ADHERE TO FOR CORROSION PROTECTION. Code minimums may need to be increased for a good serviceable condition. Architectural reveals in spandrels may dictate reinforcing location. Provide 1 1/2" clearance to top steel in prestressed members and 2" or 2 1/2 bar diameter in non-prestressed elements. Use flat sheets of welded wire mesh or bars in tees (do not allow rolls) 2) Where deicing salt is used, use non-corrosive reinforcing for reinforcement within top 2 1/2" of the concrete slab (i.e. epoxy-coated rebar, fibermesh reinforcing, and galvanized rebar) 3) Provide a minimum of 1/4" per foot slope to drain and an adequate number of drains and 4) Seal all joints between double tees, walls, beams, etc., with a flexible waterproofing sealant.

3. CONSTRUCTION RELATED PROBLEMS

Problems	Proposed Solution
a. Mislocated anchor bolts.	See Paragraph 1.f.
b. Inadequate air entrainment.	Conform to Specifications: 5% ± for precast.
c. Insufficient construction bracing.	Precaster to prepare erection plans for contractor and erector's use.
d. Failure to grout base plate after column or wall is plumbed. Placing floors above may cause concrete failure.	Contractor and testing laboratory to monitor.
e. Improper placement of bearing pads.	See paragraph 1.h.
f. Failure to cold galvanize welded connections.	Contractor and testing laboratory to monitor.
g. Scheduling: Pieces damaged in transit or erection may have to be recast and thereby cause delays or redirection of erection.	Contractor/Architect to review individual cases. Contractor to submit repair to Architect/Engineer for approval. Generally, patches lead to premature deterioration. Sealed cracks should not be accepted without a thorough review of the long term effects.
h. Concrete cracks where embeds are welded together.	Caused by expansion of embeds due to welding heat. Use intermittent welds or cool plate during welding.

4. DESIGN RELATED PROBLEMS

Problem	Proposed Solution
a. Competitive precast bid: Precasters want to bid project using their standard formwork (column & haunch size, I.T. width, tee depth) and details. These generally don't conform exactly to drawings and specifications, making bid comparison difficult and creating a period of negotiation after precaster selection. In the negotiation phase discrepancies are resolved, but often lesser solutions are accepted by the owner due to economic incentives offered by the precaster.	The drawings should state that the base bid for the job conform exactly to the drawings and specifications. All proposed contractor deviations from the details and specifications should be itemized and submitted as deduct alternates. The economic benefits can then be compared to the reduction in long term quality.

- | | |
|--|--|
| b. Division of design: Precasters typically design the major prestressed members (tees, I.T.'s, and L beams). There is a cost incentive to design members as close as possible to minimum code allowables. However, there are cases where engineering judgement should dictate alternate design or an increase over code minimum design. | Engineer-of-record should identify any areas of concern and provide design, or limitation of design, on contract documents. Examples: design of corbels, maximum allowed tensile stress in pretensioned members, areas to be designed for increased loads, and detailing 8" minimum beam ledge lengths to ensure adequate tee bearing. |
| c. Insufficient bearing due to a member being skewed in plan. | Detail extra bearing length. The end of the member will need to be cast with a skew to maximize bearing length. |
| d. Spalling and cracking of beam ledge due to concentrated load being located near the end of the ledge. | Lay out tees so as to avoid a stem near the end of the ledge. Reinforce ledge based on a smaller effective width. Detail continuous ledge reinforcing to be developed at the end. |
| e. Spalling and cracking of beam ledge at the column corbel. | Detail ledge so it does not bear on column corbel. Terminate ledge at edge of corbel or locate pad under stem of beam only. |
| f. Torsional cracks in spandrel beams. | Consider and design for eccentricity on ledges, loads placed inside the assumed critical section, and reduction of member depth at dapped ends. |
| g. Concrete cracks at embedded metal where members are welded together. | Avoid welding precast members together when possible. If welding must be done, try to make connection flexible by using an angle as a common connector in lieu of a plate. Reinforce around embeds to keep cracks closed. |

5. MAINTENANCE RELATED PROBLEMS

Problem	Proposed Solution
a. Failure to: 1) Replace sealer on tee deck and sealant in joints 2) Keep drain lines free and clean 3) Repair leaks 4) Clean expansion joints of dirt and debris 5) Clean and paint rusting embed plates 6) Report and repair cracked members 7) Clean and repair spalled areas and 8) Identify and repair areas which pond water.	Establish and maintain regularly scheduled maintenance. All items 1 through 8 should be included on a checklist. See Section G - "Maintenance Requirements."
b. Failure of sealers, sealants, or waterproofing due to incorrect installation or insufficient amounts.	Avoid by having a technical representative of the supplier at the jobsite and to affirm, in writing, that the product was used correctly. [5]

G. MAINTENANCE REQUIREMENTS

The most important factor in extending the life of a parking structure is a regular maintenance program. Maintenance programs should include the following items:

Waterproofing:

- a. Expansion joints in floors.
- b. Sealant at joints.
- c. Waterproofing sealer on all levels.

Nearly all waterproofing systems have finite life spans. Elastomeric materials used for joint sealant and expansion joints commonly carry a manufacturer's warranty of three years but their life expectancy is five to 20 years. Materials in areas exposed to direct sunlight often have a shorter life span than in areas not exposed.

It is recommended that all areas of parking garages be inspected for water leakage semiannually. Where leaks occur, repair or replace the waterproofing element as soon as practical. Spot repairs are usually more economical, until about 30% to 50% of the element needs repair, at which time total replacement should be considered. [3]

- a. "T" type expansion joints have a traffic plate which needs inspecting when the cover material is being replaced. These plates normally last longer than the cover material, unless leaks were not repaired promptly. Replacing these plates increases cost of the repair by 25%.
- b. The greatest expense of replacing polyurethane joint sealant is removing the old sealant, which can increase replacement cost up to 2 1/2 times the original installation cost.
- c. Penetrating sealer is easy to replace. No preparation is required unless the surface is extremely dirty, in which case water or shot blasting may be required prior to applying new sealer. In harsh, cold climates, all slabs should be resealed every two to three years.

Drains: Drains should be checked after heavy rains for leaks and clogging. A clogged drain can create ponding on the deck, leading to concrete deterioration.

Embedded Plates: Any steel showing signs of corrosion should be cleaned and painted. Corrosion can cause rust streaks on the concrete below, as well as lead to possible structural damage if not attended to.

Cracks: When water enters cracks, it can corrode the reinforcing. Corroded reinforcing causes concrete expansion, creating spalling and loss of reinforcing strength. For this reason fill cracks with epoxy or sealant to seal out water.

Surface Patches: Sawcut 1/2" to 3/4" deep around patched area. Chip out, clean, apply bonding agent, and fill with non-shrink patching mortar.

Ponding: Ponded water causes rapid deterioration of the waterproofing material and penetrates the concrete, with the same results as stated in Item 4 (Cracks). Ponding is caused by faulty drains, bad erection, or poor design. The specifications should require the deck to be tested for ponding by the Contractor before leaving the project. The Architect/Engineer can recommend solutions for problems.

Cleaning: Cleaning should include a regular sweeping (preferably once a month) and a wash down twice a year. [6] As a minimum, decks in harsh, cold climates must be washed down every spring.

Inspections: Garages should be inspected every year. Regular inspection for the above items can detect problems before they become too serious or more costly to correct.

H. COST ESTIMATE

Construction Estimate: The construction quantities tabulated below are based on 1/4 of the total area of a typical floor of the garage illustrated earlier in this chapter. These quantities could be used for comparative cost of structural construction and waterproofing. Other items such as plumbing, lighting, striping, stairs, foundations, elevators, etc., would be similar in cost for all six systems and therefore are not included. General conditions, overhead, and profit have also been excluded. For sealer quantities listed below, refer to the cost estimate for the “Topped Precast Concrete” system (Chapter 3) for assumptions.

DESCRIPTION	QUANTITY	UNIT
10 DT 26 TEES	14,335	S.F.
P/C SPANDREL	167	L.F.
P/C PANEL	88	L.F.
P/C I.T. BEAM	43	L.F.
P/C WALL PANEL	760	S.F.
P/C COLUMN (24”X24”)	110	L.F.
SEALERS (AVERAGE)	14,335	S.F.
SEALANT	1,915	L.F.
AREA ESTIMATED		14,500 S.F.

Maintenance Estimate: Maintenance quantities tabulated below are based on 1/4 of the total area of a typical floor of the garage illustrated earlier in this chapter. These quantities could be used for comparative cost of maintenance items related to this particular system. Other items such as sweeping, wash downs, drain cleaning, restriping, etc., would be similar in cost for all six systems and therefore are not included.

DESCRIPTION	QUANTITY	UNIT
REPLACE SEALANT	1,915	L.F.
REPLACE SEALERS (AVERAGE)	14,335	S.F.
AREA ESTIMATED		14,500 S.F.



Post-Tensioned Beam and Slab 5

CHAPTER 5

POST-TENSIONED BEAM AND SLAB

A. DESCRIPTION

Post-tensioned, cast-in-place concrete beams and slabs. Slabs are normally 5" to 7 1/2" thick. Beams are spaced 25'-6" to 30'-0" feet on center, supported by cast-in-place concrete columns. Edge beams parallel to slab span are not required, but often the slab is thickened to 8"-10" along the edge.

B. ADVANTAGES

Eliminates Walls - With rigid frame construction, it is possible to eliminate shear walls and slab cracking problems associated with shear walls. Elimination of shear walls also improves ventilation and security.

Structural Stability - Post-tensioned, cast-in-place concrete gives better overall structural stability and performance. It also eliminates weld plates and exposed steel connections.

Appearance - Post-tensioning provides for virtually joint-free and crack-free construction. There are no connections to pull apart.

Low Maintenance - No painting required. Very little joint sealant to replace. Watertight throughout. Virtually eliminates corrosion of rebar and subsequent spalling. It especially reduces the need for waterproofing membranes and the maintenance of the waterproofing.

Construction Advantages - No heavy members to haul, lift, or store. This is especially advantageous in tight construction sites with limited storage or access. Local labor and materials can be used with cast-in-place construction.

Functional Aspects - Cast-in-place construction allows flexibility for complex shapes, irregular sites, and curved ramps. Member proportions can be adjusted to conform to architectural requirements. Long cantilevers, due to restricted column locations, are more easily accomplished with cast-in-place, post-tensioned concrete.

Deck Durability - A minimum amount of post-tensioning in both directions keeps cracks from forming and closes up any cracks that occurred before stressing. There is less surface flaking and more resistance to freeze/thaw cycles. Also, the need for control joints is eliminated.

Future Expansion - Future expansion is often easier to accomplish than with precast because of the limit on the distance a crane can reach for placing heavy precast members.

Fewer Joints - Since the deck is cast-in-place and post-tensioned, few joints are required. This also reduces the need for joint sealants and their maintenance.

Lighting - Lighting is often easier to design and detail and can cover a larger area than with a precast system. Typically, the beams are spaced farther apart than precast tee stems or pan joists, making illumination more efficient.

Drainage - Compound drainage slopes are quite easily accomplished and there are no high cambers to overcome.

C. DISADVANTAGES

Congestion Problems - Reinforcing and tendons must be carefully detailed at joints to minimize congestion.

Construction Time - Forming, reinforcing, concrete placement, stressing, and form removal may increase construction time.

Inspection - Rigid quality control is required in the field during construction. Tendon placement, cover, and stressing must be checked.

Design Problems - Long term volume changes, due to creep and shrinkage, are high and must be accounted for in design. Pour strips must be provided along rigid walls when they are not centrally located. Columns must be designed for extra shear and moment caused by floor stressing.

Expansion Joints - May require more closely spaced expansion joints than with precast.

Tendon Blowout - If tendons are not placed properly with the specified drapes and edge distances, the tendons can create tension in the concrete and blow out. This also happens where weak concrete or pump priming grout is cast around a tendon.

Future Additions - Formed cast-in-place concrete construction on top of an existing structure requires backshoring down through the existing facility, whereas precast and steel systems do not.

D. RECOMMENDED DETAILS

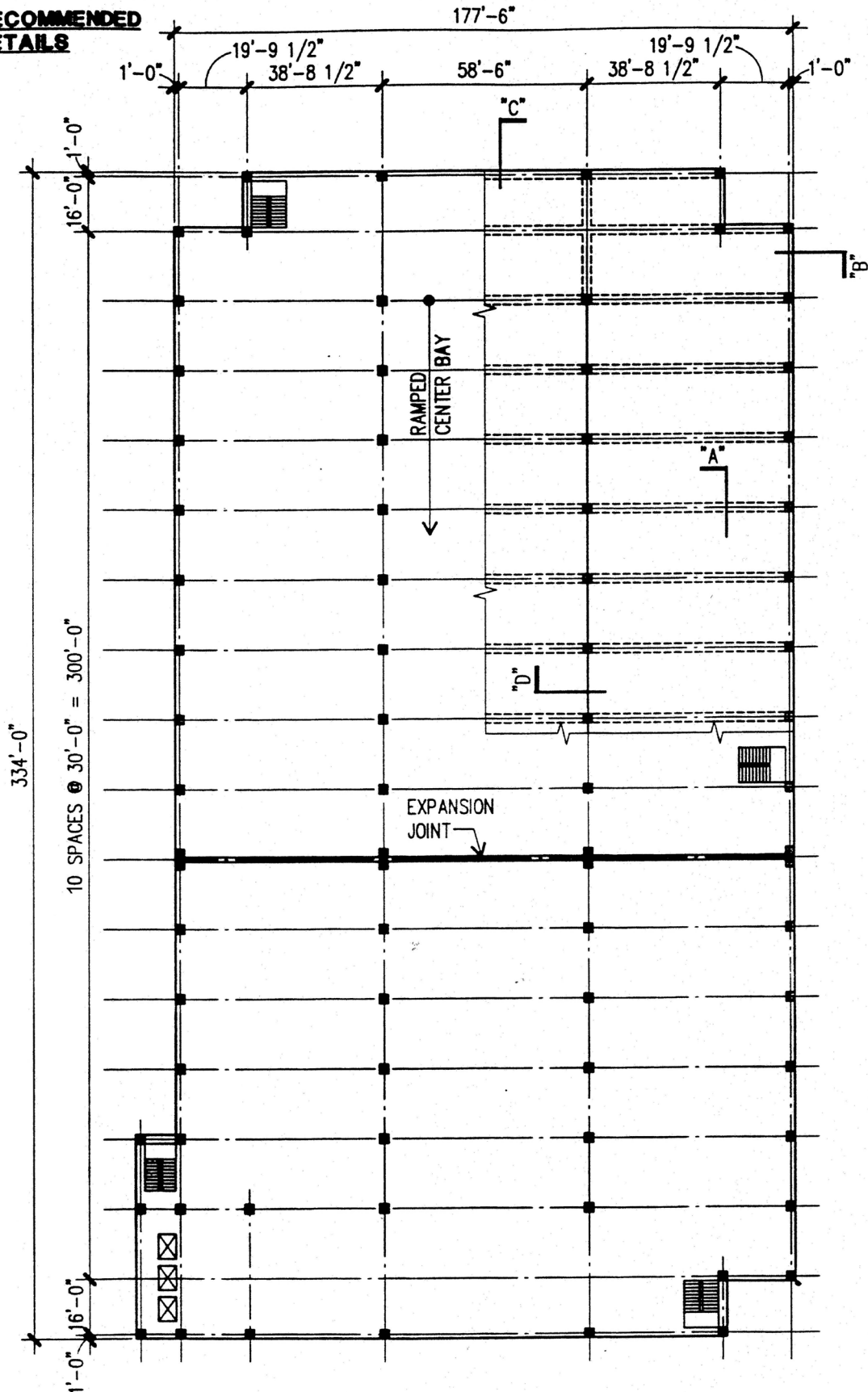

TYPICAL FLOOR FRAMING PLAN

1"=40'-0"

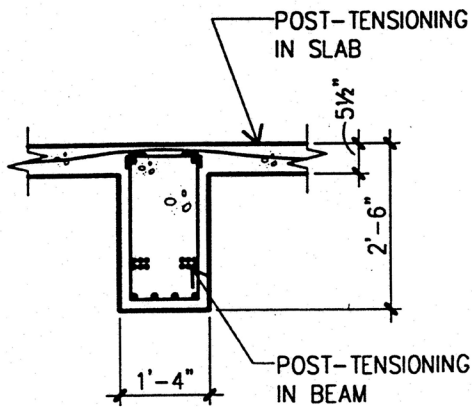

A TYPICAL POST-TENSIONED BEAM

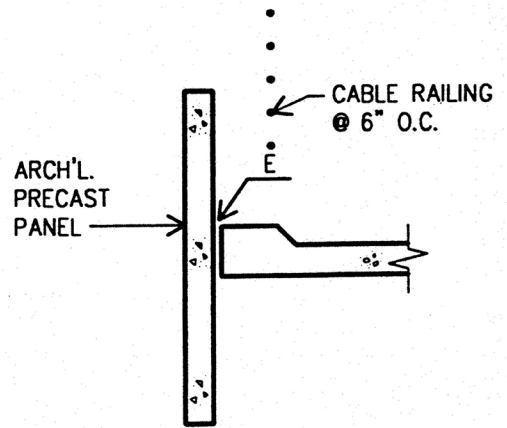

B

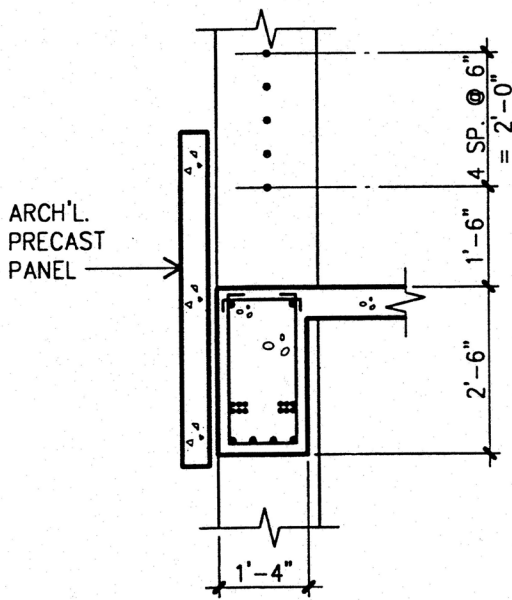

C

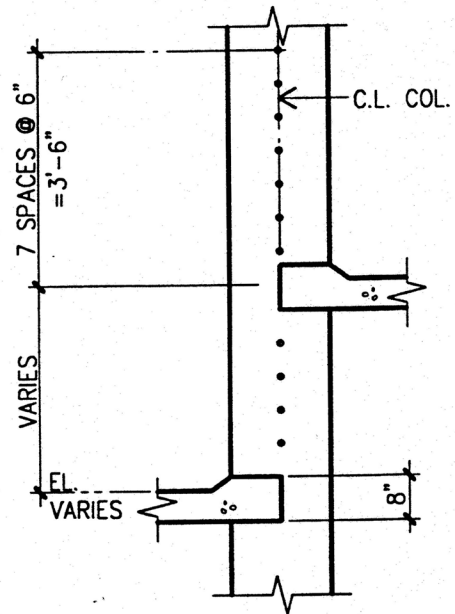

D

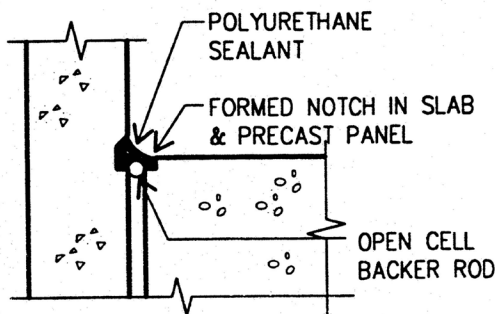

E ROOF LEVEL ONLY

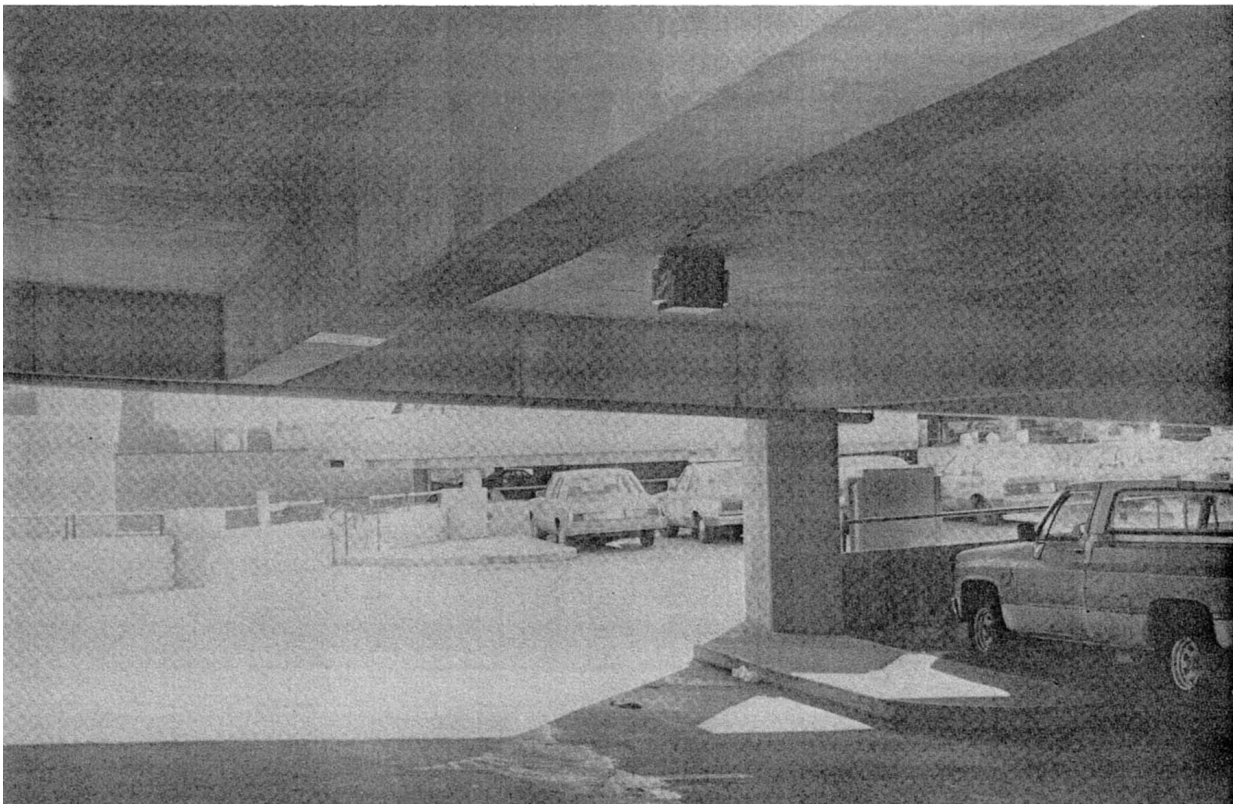

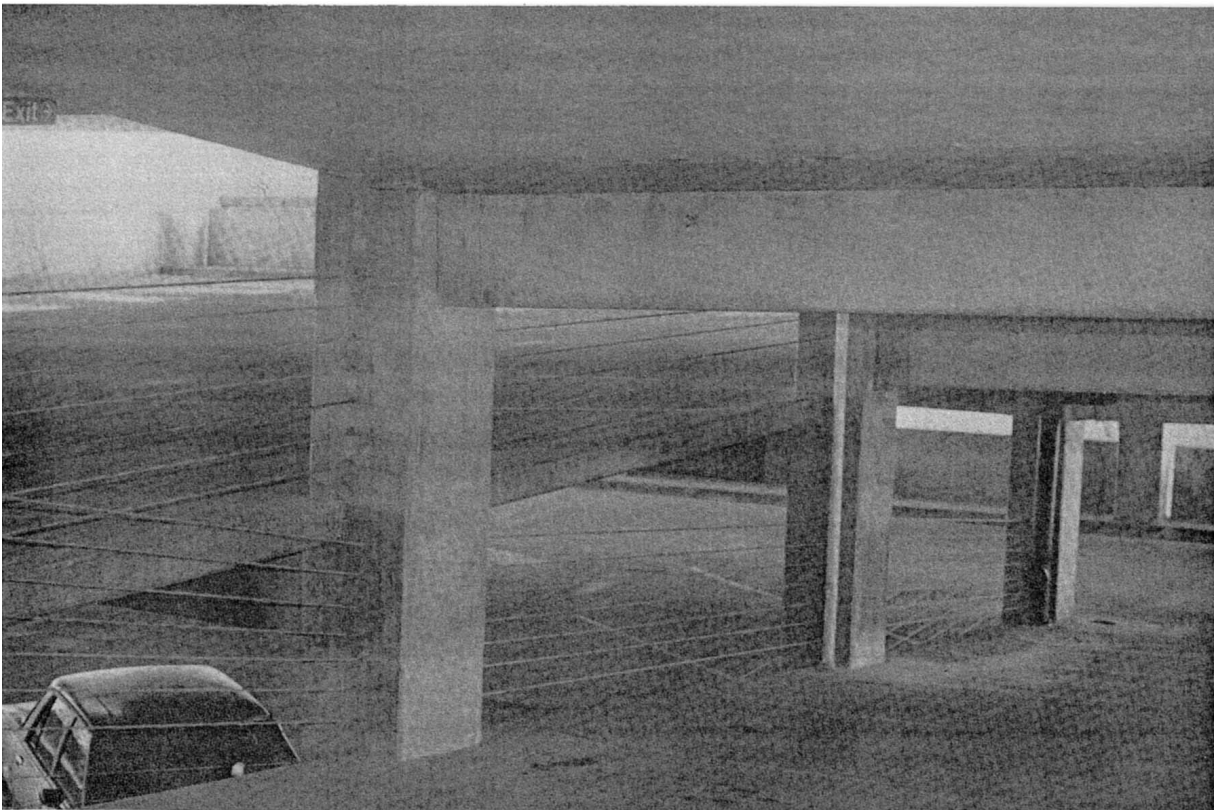
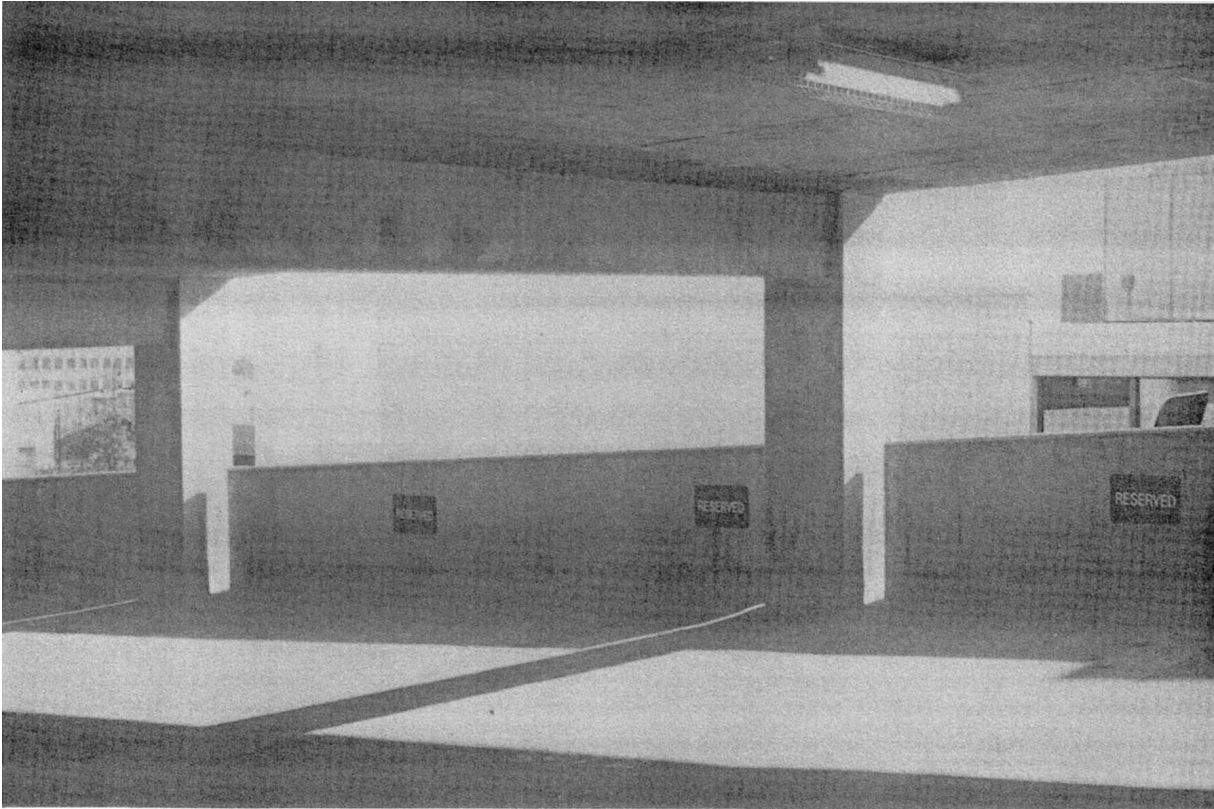

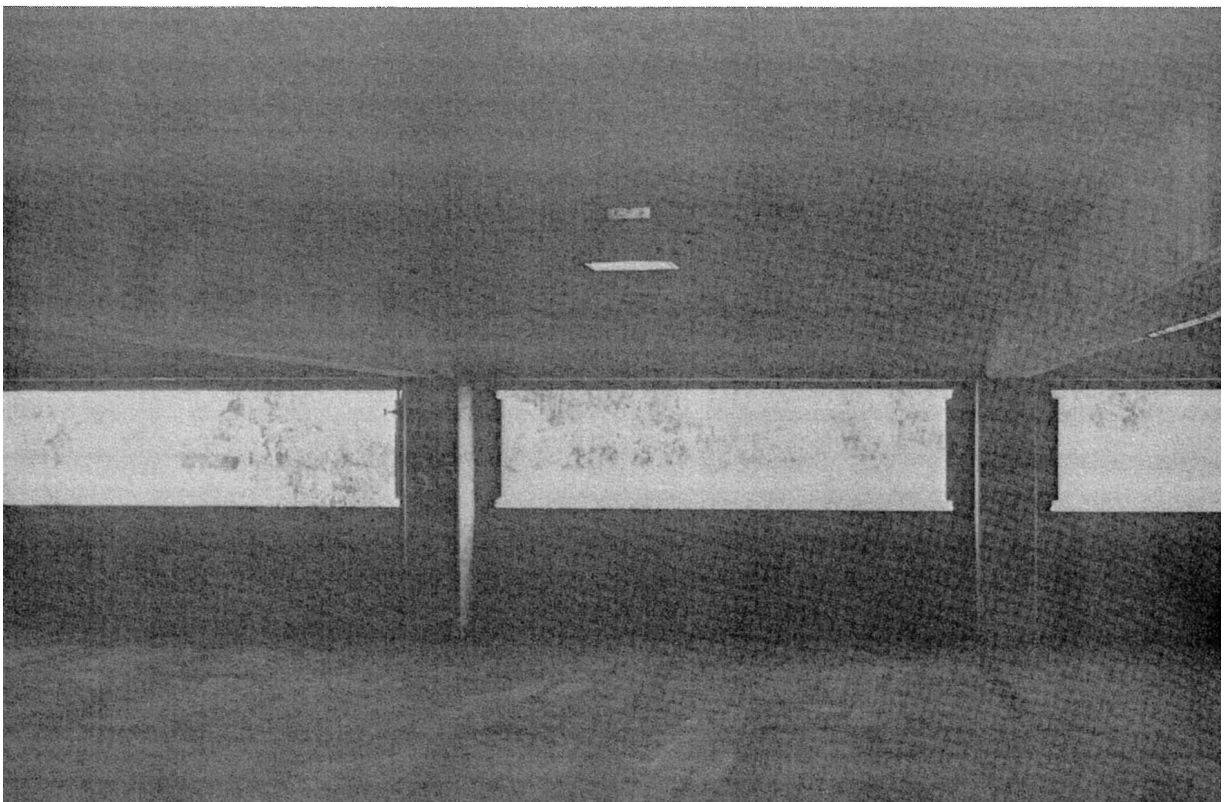
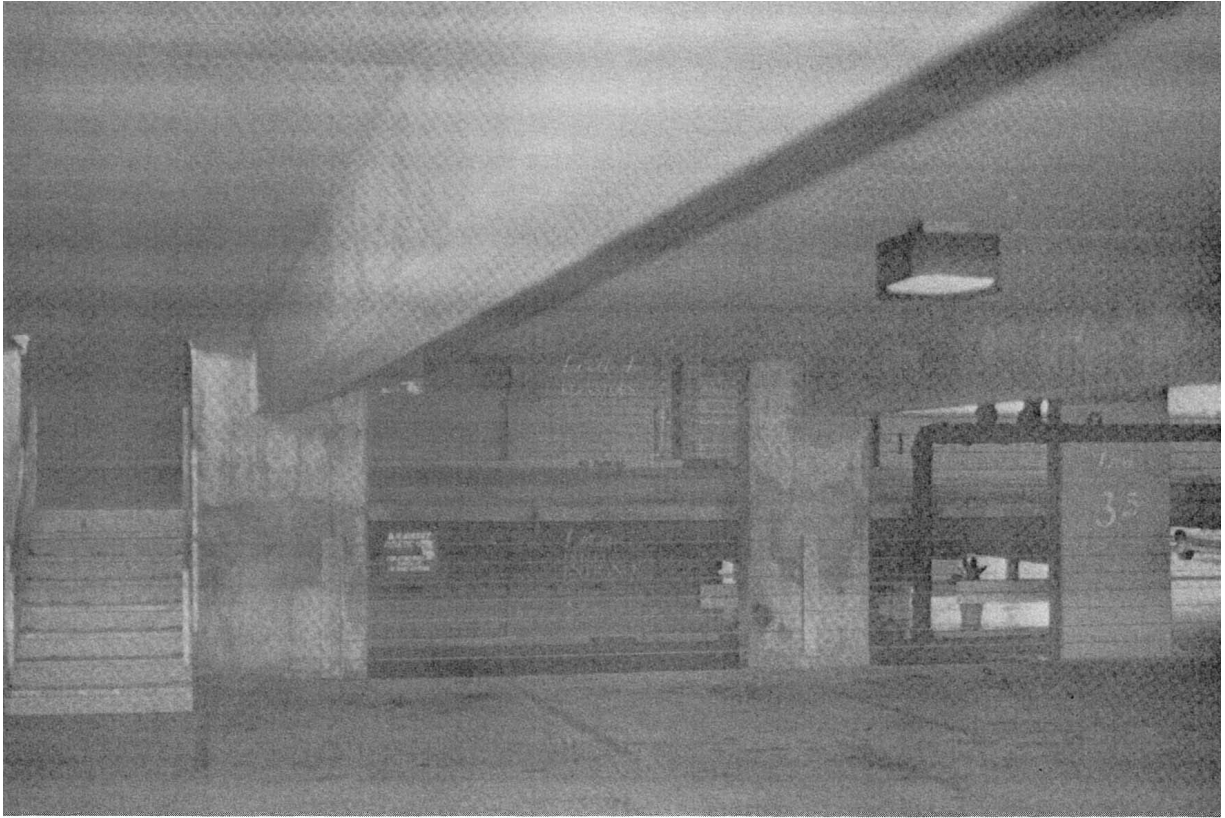



E. KEY SPECIFICATION ITEMS

1. Provide a minimum slab compressive stress of 175 psi in both directions.
2. Provide encapsulated tendons in plastic sheathing to protect them from moisture and prevent corrosion. Paper wrapped tendons are no longer used and are unacceptable.
3. Provide more than code minimum concrete cover over tendons and reinforcing. Preferably use 1 1/2" clear to steel at top of slab and 2 1/2" or 2 1/2 x bar diameter clear to main steel and tendons at top of beams (2" minimum cover to stirrups).
4. Provide 5% to 7% of air entrainment in the concrete mix to reduce surface scaling and flaking. Admixture must conform to ASTM C 260.
5. Use 5000 psi (minimum) hardrock concrete with 1" aggregate.
6. Limit water/cement ratio of concrete to 0.40. This provides a higher strength concrete with lower permeability, less shrinkage, and better durability. This mix produces less bleedwater so finishing can proceed rapidly.
7. Do not trowel the concrete slab before bleedwater evaporates. Doing so will reduce air entrainment in the top surface, which decreases its resistance to scaling and flaking. Early troweling also drives the moisture back into the concrete, increasing the water/cement ratio. [7]
8. Grind, clean, and seal all floor construction joints. Use a top quality flexible polyurethane sealant.
9. Use a good quality, urethane-based penetrating sealer on all concrete parking surfaces, except the top level, to prevent water and chloride infiltration. On the top level, a silane-based penetrating sealer should be used. Also, the use of a waterproofing membrane should be considered over any occupied space.
10. Use a proven "T" type expansion joint cover. The "T" type expansion joint requires a recess in the top surface which forms a "T" with the joint. A prefabricated joint seal is set in the recess.
11. Conform to the Post-Tensioning Institute's "Specifications for Unbonded Tendons," category "Structures in Corrosive Environments."
12. Provide an upturned thickened edge on slabs without edge beams. This will increase stiffness to help prevent visible sagging at the edge. It will also simplify post-tensioning anchor placement and create a gutter edge to prevent rainwater from running over the edge of the slab.
13. Use a medium broom or float swirl finish on all surfaces with a slope less than 10%. Avoid a hand troweled finish. Ramps with slopes greater than 10% should receive a raked finish parallel to the slope.
14. All admixtures, other than air entrainment, must conform to requirements of ASTM C 494. Admixtures containing calcium chloride should be prohibited.
15. Due to the low slump produced by limiting the water/cement ratio to 0.40, specify that a properly designed superplasticizer be added to the concrete mix to improve the fluidity.
16. In harsh cold climates, where salt is used for deicing, add calcium nitrite to the concrete mix (two gallons/cubic yard). This is expensive and a reasonable alternate may be found, but conform to local practices as a minimum solution.

TRADITIONAL DOWNTURN SPANDREL BEAM



**SOUTHERN METHODIST UNIVERSITY
HILLCREST GARAGE**

Dallas, Texas

DATUM UPTURN SPANDREL BEAM CONCEPT

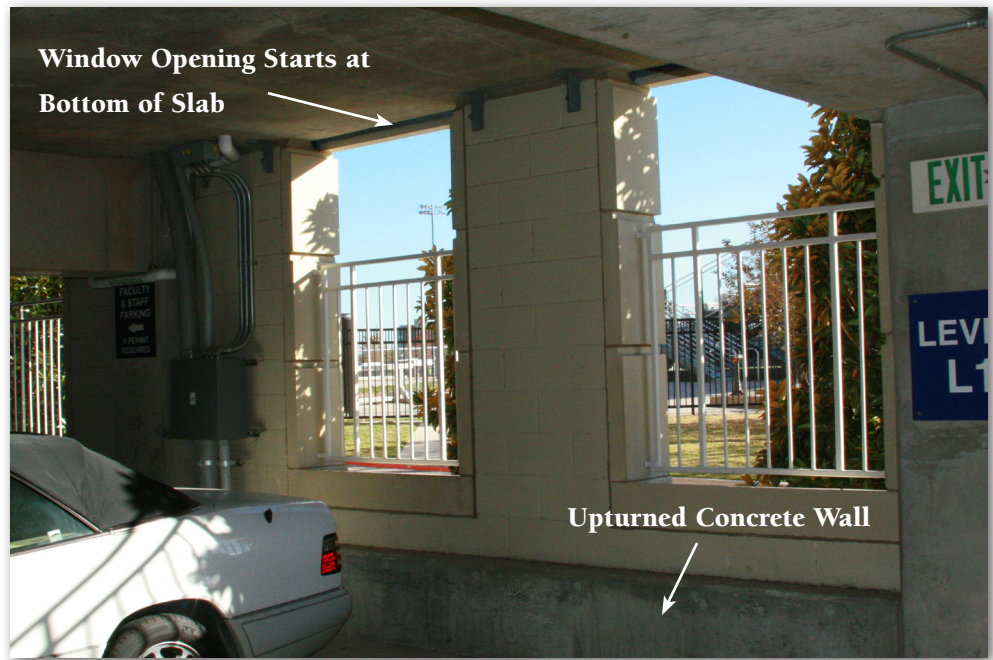

**SOUTHERN METHODIST UNIVERSITY
BINKLEY GARAGE**

Dallas, Texas

DATUM UPTURNED BEAM CONCEPT

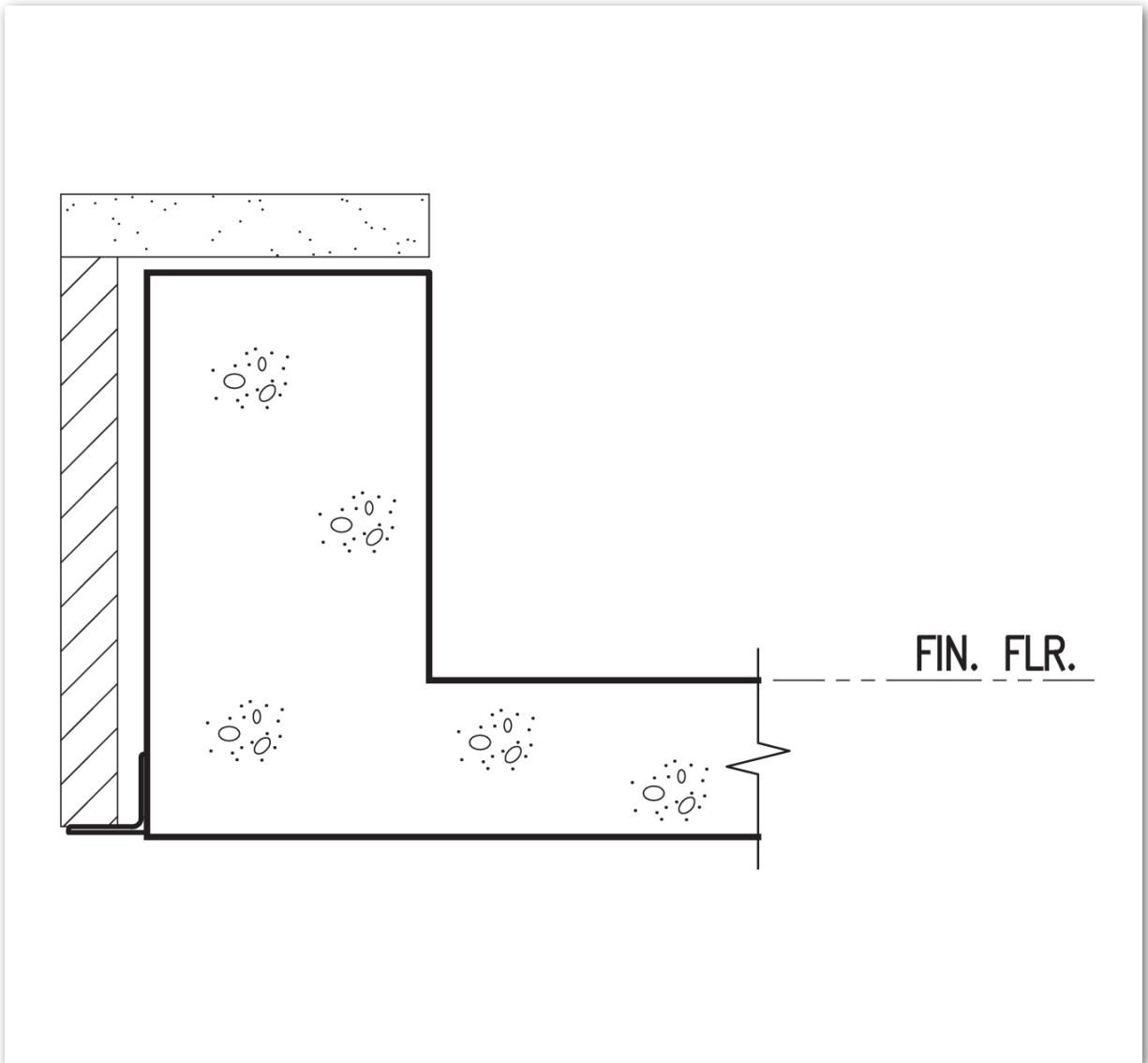

- 17. Water cure the concrete for seven days. This will greatly enhance the durability of the concrete. Alternate curing compound solutions must be equal in quality to water curing, be applied immediately, and be properly maintained. CURING COMPOUND MUST BE COMPATIBLE WITH SEALER.
- 18. Microsilica (or “silica fume”), when used in conjunction with a superplasticizer will produce a denser, higher strength concrete with greatly reduced permeability. It is not widely used yet, but is gaining acceptance and should be considered.

F. DISCUSSION OF PROBLEMS AND PROPOSED SOLUTIONS

The following is a list of problems frequently encountered in garage design and construction, along with corresponding solutions to these problems. This document should be reviewed by the contractor and subcontractors. It emphasizes items which are not acceptable construction practice.

1. FABRICATION AND ERECTION TOLERANCES

Problem	Proposed Solution
a. Tendons with sheathing too thin, out-of-round, torn, or with exposed rusting cable.	Contractor should ensure that tendons have a plastic sheathing a minimum of 40 mils thick and that this sheathing is not damaged or the cable exposed during shipping, storage, and placement.
b. Tendons not placed within specified dimensional tolerance.	Testing laboratory must review placement and enforce corrective procedures before concrete is cast.
c. Final measured elongation not within 7% ± of design elongation.	Contractor should restress tendons not within tolerances or determine the reason for the discrepancy.

2. ENVIRONMENT RELATED PROBLEMS

Problem	Proposed Solution
a. Failure to account for expansion and contraction over range of temperature experienced.	<p>For buildings longer than 250 ft in one direction, consider adding pour strips. For buildings longer than 300 ft, provide expansion joints. Design expansion joint for movement caused by a 100 degree variation in temperature (minimum) or higher if local conditions dictate. The top deck is subjected to direct sunlight and/or ice and should be designed for an additional 30 degrees variation. This extra temperature movement in top deck will add stress to the top column tier.</p> <p>Design expansion joint for movement caused by a 100 degree variation in temperature, minimum, or higher if local conditions dictate. Top deck is subjected to both ice and sunlight and should be designed for 30 degrees higher variation in temperature. This produces stresses in the top story columns. These temperature variations result in design temperature deltas of approximately 50 and 65 degrees F, respectively.</p>
b. Wrong type and construction of expansion joint.	Use “T” type expansion joint. Locate expansion joint at high point of floor slope or thicken slab at expansion joint to direct water away from the joint when applicable (on a level or low area). Keep joint clean and free to move.
c. Cracking and associated problems.	Cracking problem is substantially less than with topped precast. Constant prestress forces tends to prevent cracks and close up existing cracks.

- d. Shrinkage cracking and flexural cracking under imposed loads.

1) Provide minimum post-tensioning force of 175 psi in slab in both directions. Minimum post-tensioning force should not drop below 125 psi when considering temperature, shrinkage, and restraints 2) Design slab and beams to have zero tension under realistic service loads (dead load plus 25 psf live load) with live load applied on all spans or on alternate (skip) spans, whichever produces the highest stress condition 3) Use a low water/cement ratio of 0.40, with a slump of 2” to 3” and maximum 1” aggregate 4) Follow ACI recommended concrete placement methods and 5) Provide proper curing with wet burlap for 7 days or with curing compound.

- e. Corrosion of reinforcement and anchorage assemblies.

Problem is minimized due to decreased cracking; however 1) At construction and expansion joints special care must be taken to ensure waterproofing of the joint to protect anchorages. Construction joints should be provided with a formed kerf filled with sealant 2) Live ends of cable should not, if possible, be terminated at an expansion joint 3) Provide adequate clear cover over all post-tensioned cables and mild steel. Use 1 1/2” clear to steel at top of slabs and 2 1/2” or 2 1/2 x bar diameter clear to main steel and tendons at top of beams (2” minimum cover to stirrups). THIS MAY BE THE MOST EFFECTIVE PRINCIPLE TO ADHERE TO FOR CORROSION PROTECTION 4) In climates where salt is used for deicing, epoxy coat all reinforcement within the top 2 1/2” of the concrete slab, including support bars for top slab reinforcement. Epoxy coat bottom reinforcement at mild reinforced pour strips 5) Apply a penetrating sealer to all levels of the garage 6) Provide a minimum 1/8” per foot slope to drain and 7) Specify encapsulated tendons.

- f. Tendon anchors rust, causing concrete staining and spalling.

1) Recess anchors a minimum of 1 1/2”. Apply bonding agent to pocket and fill with non-shrink grout to waterproof anchor. This must be done within 15 days after removing tails 2) Do not place anchors near drains or in planter boxes 3) Couplers can be enclosed in housings and filled with grease 4) In harsh cold climates, where salt is used for deicing, epoxy coat all post-tensioned slab and beam anchors after tendons are stressed and tails are cut and 5) specify encapsulated tendons.

3. CONSTRUCTION RELATED PROBLEMS

Problem	Proposed Solution
a. Improper cover or drape.	Testing laboratory must review placement and enforce corrective procedures before concrete is cast.
b. Tear in tendon sheathing or sheathing is stripped back at anchors.	Use two layers of polyethylene tape to repair tears in sheathing and to wrap tendon tight to all anchorages.
c. Tendon kinked at openings, conduit, or mild steel. Displacement due to foot traffic during concrete pour can cause slab spall when cable is stressed.	Contractor and testing laboratory must monitor tendon and concrete placement.

- d. Tendon breaks during stressing operation or actual elongation does not agree with anticipated elongation. Provide enough capacity in design to allow a reserve capacity to compensate for a small error. Review stressing records for information required. Have coordination meetings with the testing laboratory.
- e. Extreme congestion of cables in major beams and at column intersections. Provide ample member size and limit stress in beams to 500 psi maximum. Review beam to column anchorage details on shop drawings.
- f. Tendon blows out of concrete as it is being stressed.
 - 1) Avoid sudden reverse drapes in tendon. Draping in tendons should be gradual and match dimensions shown on shop drawings
 - 2) Ensure adequate cover over tendons
 - 3) Do not allow pump priming grout to remain in pour, this grout creates a weak area in the slab
 - 4) Do not allow concrete to be dropped directly on top of a tendon, weight of the concrete can knock it out of alignment
 - 5) Provide proper tendon support with the necessary height and spacing of chairs.

4. DESIGN RELATED PROBLEMS

Problem	Proposed Solution
a. Excessive deflections.	Select post-tensioned slab thickness based on maximum span-to-depth ratio of 45. Select beam size for a maximum span-to-depth ratio of 28 (simple span).
b. Failure to recognize congestion at beam to column junctures.	It is important that the designer recognize and plan for congested areas. He must be familiar with anchor systems and sizes.
c. Concrete spalls off bottom of beam below tendons, due to tendons being placed solidly across the beam.	Detail tendons to be bundled allowing concrete to fall down the middle of the beam to the bottom of the form. The bottom concrete cover must be adequately tied into the rest of the beam.
d. Stressing problems due to offset in floor levels at ramps. Examples Access to stressing ram, Construction joints between bays, Column construction joints and Congestion.	Recognize ramp divergence from flat floor as a problem area. Detail construction joints in slabs, beams, and columns. Detail anchorage locations. Be familiar with anchor sizes and required ram clearances.
e. Anchor pockets conflict with vertical column reinforcing. Loss of column strength due to pockets required for anchors.	Detail vertical reinforcing at pockets and design column based on this bar arrangement and reduced column section.
f. Cracks occur at restraining walls and columns. Construction joints open up.	<u>Locate restraining elements near center of structure. Use pour strips along walls not centrally located. Rigid elements which are not centrally located should be permanently separated.</u> Detail this on the drawings. Evaluate and note pouring and stressing sequences on the drawings.

- g. Column cracking. Design columns for extra forces due to post-tensioning and thermal stresses. Add ties in ramp columns where floors offset. Add rebar in tops of columns for continuity moments.
- h. Interior columns at ramps difficult to cast with higher strength concrete due to short sections. Design interior columns at ramps with same strength concrete as floor. It is not practical to cast short sections of concrete columns with a higher strength concrete than is used on the floor.

5. MAINTENANCE RELATED PROBLEMS

Problem	Proposed Solution
a. Failure to 1) Keep drain lines free and clean 2) Repair leaks 3) Replace sealer on concrete deck and sealant in joints on all floors 4) Clean expansion joints of dirt and debris 5) Clean and paint rusting embedded plates 6) Report and repair cracked members 7) Clean and repair spalled areas and 8) Identify and repair areas which pond water.	Establish and maintain regularly scheduled maintenance. Items 1 through 8 should be included on a checklist. See Section G - "Maintenance Requirements."
b. Premature failure of sealers, sealants, or waterproofing due to being installed incorrectly or at insufficient rates.	Avoid by having a technical representative of the supplier on the jobsite to affirm in writing that the product was used correctly. [5]

G. MAINTENANCE REQUIREMENTS

The most important factor in extending the life of a parking structure is a regular maintenance program. Regular maintenance programs should include the following items.

Cracks When water enters cracks, it can work its way to the reinforcing. Corrosion of the reinforcing causes expansion in the concrete, creating spalling and loss of reinforcing strength. For this reason, any cracks should be filled with epoxy or sealant to seal out the water as soon as possible.

Surface Patches Sawcut 1/2" deep around the damaged concrete. Chip out, clean, and fill with non-shrink, high strength patching mortar.

Drains Drains should be checked after heavy rains for leaks and clogging. A clogged drain can create ponding on the deck, leading to slab deterioration.

Ponding Ponded water will cause rapid deterioration of the waterproofing material and then penetrate the concrete. The result will be the same as described for cracks. Ponding is usually caused by faulty drains, concrete irregularities, formwork settlement, or poor design. The specifications should call for the deck drainage to be tested for ponding by the Contractor before he leaves the project. The Architect/Engineer can recommend solutions for problem areas.

Cleaning Cleaning should include a regular sweeping (preferably once a month) and a wash down once or twice a year. [6] As a minimum, decks in harsh cold climates must be thoroughly washed down every spring to eliminate salt residue.

Waterproofing Clean and reapply penetrating sealer to slabs every five to 10 years. If the surface is extremely dirty, water blast or shot blast preparation might be required. In harsh cold climates, reapply sealer every two to three years.

Expansion Joints Replace worn or deteriorated expansion joint seals.

Inspection Garages should be inspected every two to three years. Regular inspections can detect problems before they become major, costly repairs.

H. COST ESTIMATE

Construction Estimate The construction quantities tabulated below are based on 1/4 of the total area of a typical floor of the garage shown in Part D of this chapter. These quantities could be used for comparative cost of structural construction and waterproofing. Other items such as plumbing, lighting, striping, stairs, foundations, elevators, etc., would be similar in cost for all six systems and therefore are not included. General conditions, overhead, and profit are also not included. For sealer quantities listed below, refer to the cost estimate for the "Topped Precast Concrete" system (Chapter 3) for assumptions.

DESCRIPTION	QUANTITY	UNIT
SLAB FORMWORK	13,672	S.F.
BEAM FORMWORK	3,388	S.F.
CONCRETE	392	C.Y.
REINFORCING	21.6	TONS
POST-TENSIONING	19,900	LB.
ARCHITECTURAL P/C PANELS	256	L.F.
COLUMN FORMS	340	S.F.
CABLE RAILS	1,600	LB.
SEALERS (AVERAGE)	14,500	S.F.
SEALANT (AT PERIM. OF TOP LEVEL ONLY - AVERAGE PER FLOOR)	51	L.F.
AREA ESTIMATED.....		14,500 S.F.

Maintenance Estimate Maintenance quantities tabulated below are based on 1/4 of the total area of a typical floor of the garage shown in Part D of this chapter. These quantities could be used for comparative cost of maintenance items related to this particular system. Other items such as sweeping, wash downs, drain cleaning, restriping, etc., would be similar in cost for all six systems and therefore are not included.

DESCRIPTION	QUANTITY	UNIT
REPLACE SEALANT (AT PERIM. OF TOP LEVEL ONLY - AVERAGE PER FLOOR)	51	L.F.
REPLACE SEALERS (AVERAGE)	14,500	S.F.
AREA ESTIMATED.....		14,500 S.F.



Post-Tensioned Pan Joists 6

CHAPTER 6

POST-TENSIONED PAN JOISTS

A. DESCRIPTION

Post-tensioned, cast-in-place concrete pan joists spaced at three to five feet on center, with a thin slab. A prefabricated metal pan form is used to form the soffit and sides of the joist and slab. Distribution ribs are located at third points in the span to help distribute heavy loads to adjacent joists.

B. ADVANTAGES

Eliminates Walls - With rigid frame construction, it is possible to eliminate all shear walls and slab cracking problems associated with shear walls. Elimination of shear walls also improves ventilation and security.

Structural Stability - Post-tensioned, cast-in-place concrete gives better overall structural stability and performance. It also eliminates weld plates and exposed steel connections.

Appearance - Post-tensioning provides for virtually joint free and crack free construction. There are no connections to pull apart.

Low Maintenance - No painting required. Very little joint sealant to replace. Watertight throughout. Eliminates corrosion of rebar and subsequent spalling. It especially reduces need for waterproofing membranes and maintenance of the waterproofing.

Construction Advantages - No heavy members to haul, lift, and store. Local labor and materials can be used with cast-in-place construction.

Functional Aspects - Cast-in-place construction allows flexibility for complex shapes, irregular sites, and curved ramps. Member proportions can be adjusted to conform to architectural requirements. Long cantilevers, due to restricted column locations, are accomplished more easily with cast-in-place, post-tensioned concrete.

Deck Durability - A minimum amount of post-tensioning in both directions keeps cracks from forming and closes up any cracks that occurred before stressing. There is less surface flaking, more durability, and more resistance to freeze/thaw cycles. Also, the need for control joints is eliminated.

Thinner Structure - With post-tensioning, structural depth is reduced. This allows for smaller floor-to-floor heights. This is particularly important in reducing excavation requirements for underground garages. There is also less deflection, thereby reducing ponding problems. Shorter floor-to-floor heights also means less ramping or reduced ramp slope.

Fewer Joints - Since the deck is cast-in-place and post-tensioned, few joints are required. This reduces the need for joint sealants and the maintenance of these sealants.

Future Expansion - Future expansion is sometimes easier to accomplish than with precast because there is a limit on the distance a crane can reach for placing precast members.

C. DISADVANTAGES

Congestion Problems - Reinforcing and tendons must be carefully detailed at joints to minimize congestion.

Construction Time - Forming, reinforcing, concrete placement, stressing, and form removal may increase construction time.

Inspection - Rigid quality control is required in the field during construction. Tendon placement, cover, and stressing must be checked.

Design Problems - Long term volume changes, due to creep and shrinkage, are high and must be accounted for in design. Pour strips must be provided along rigid walls when they are not centrally located. Columns must be designed for extra shear and moment caused by floor stressing.

Expansion Joints - May require expansion joints spaced more closely than with precast.

Increased Weight - Long-span pan joint construction typically requires more concrete per square foot than other systems. This increases load on columns and footings.

Tendon Blowout - If tendons are not placed properly with the specified drapes and edge distances, the tendons can create tension in the concrete and blow out. This also happens where weak concrete or pump priming grout is cast around a tendon.

Lighting - Due to the closely spaced ribs, lighting is not easily or efficiently accomplished.

Future Additions - Formed cast-in-place concrete construction on top of an existing structure requires backshoring down through the existing facility, whereas precast and steel systems do not.

**D. RECOMMENDED
DETAILS**

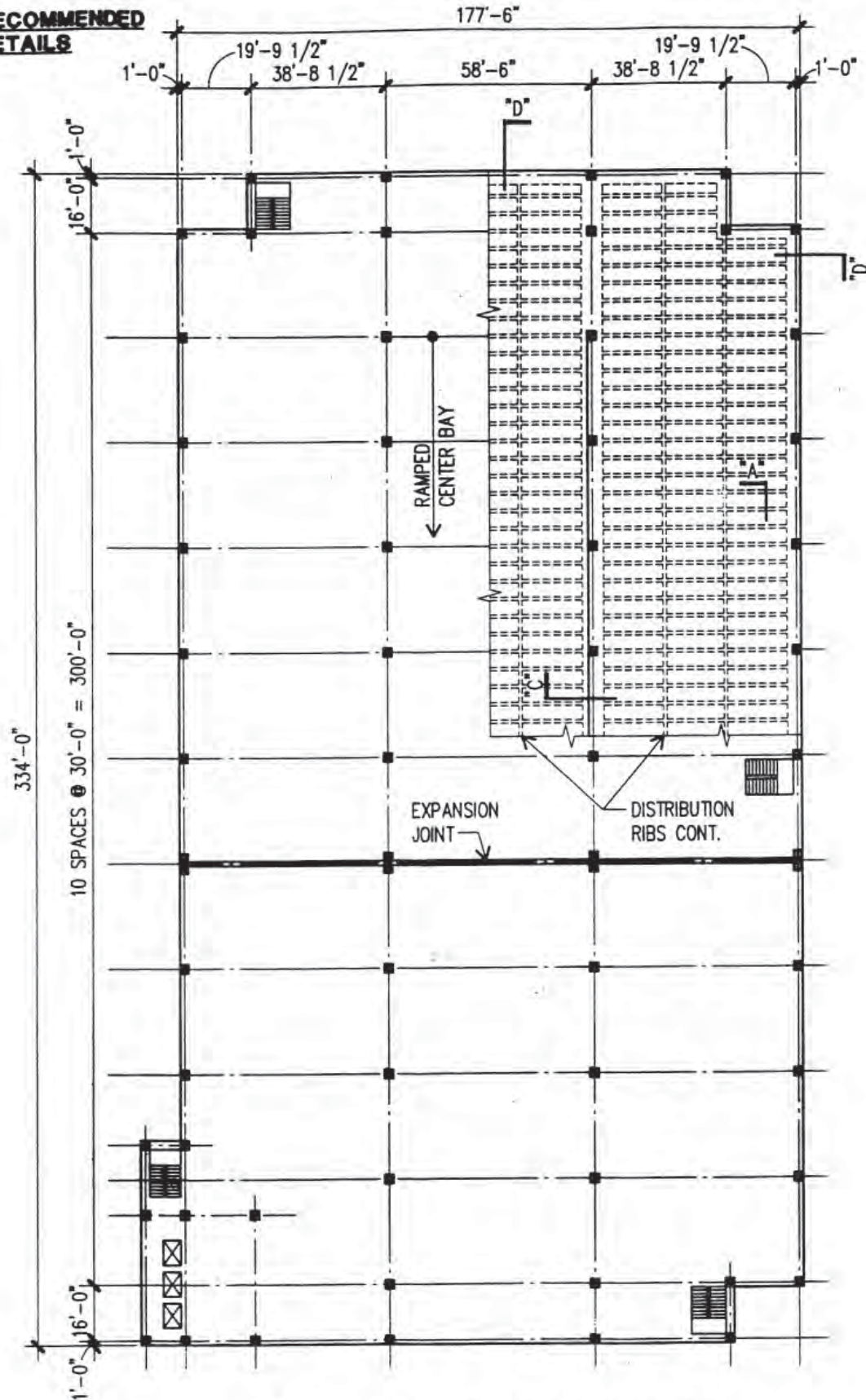

TYPICAL FLOOR FRAMING PLAN

1" = 40'-0"

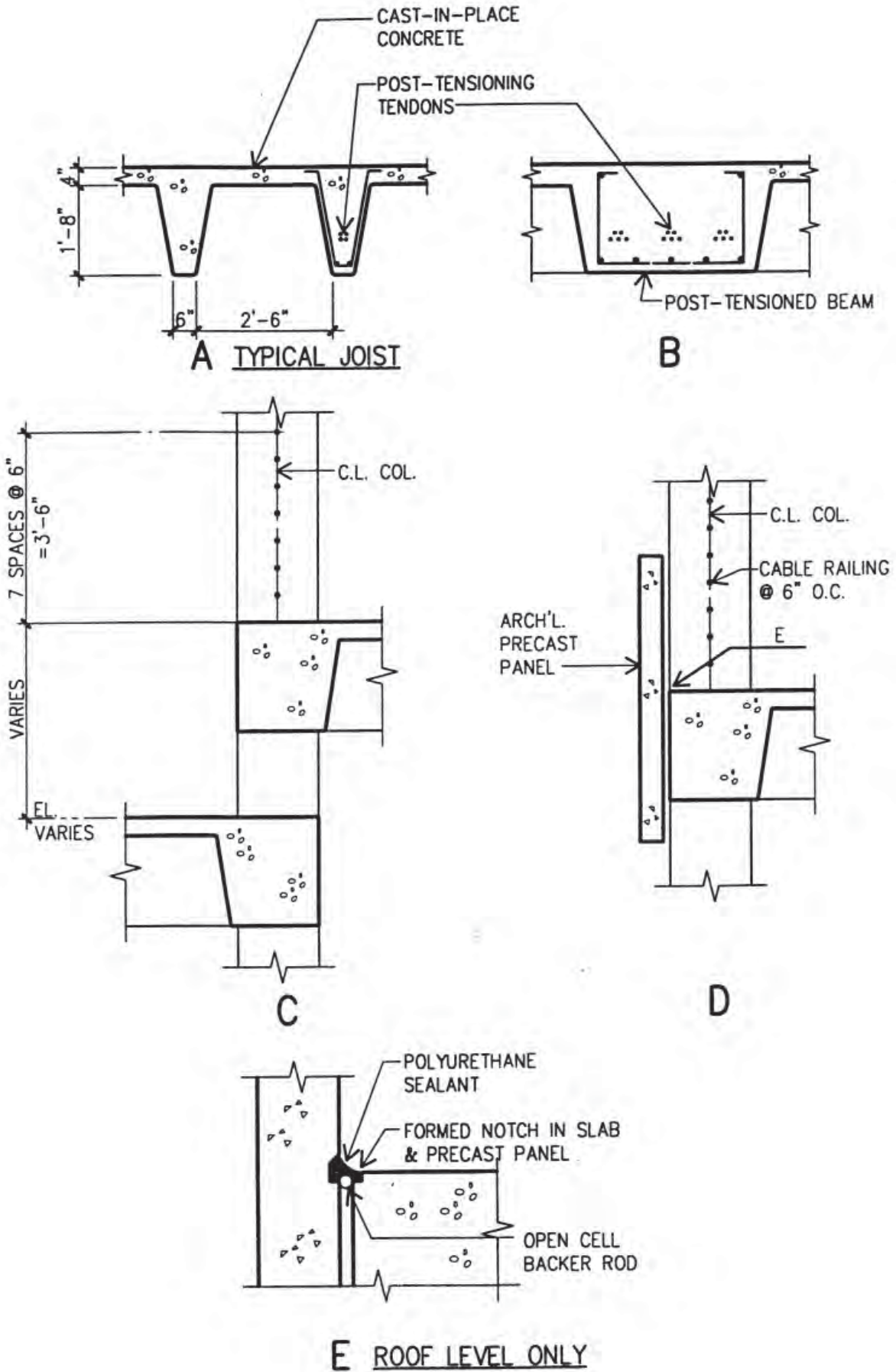

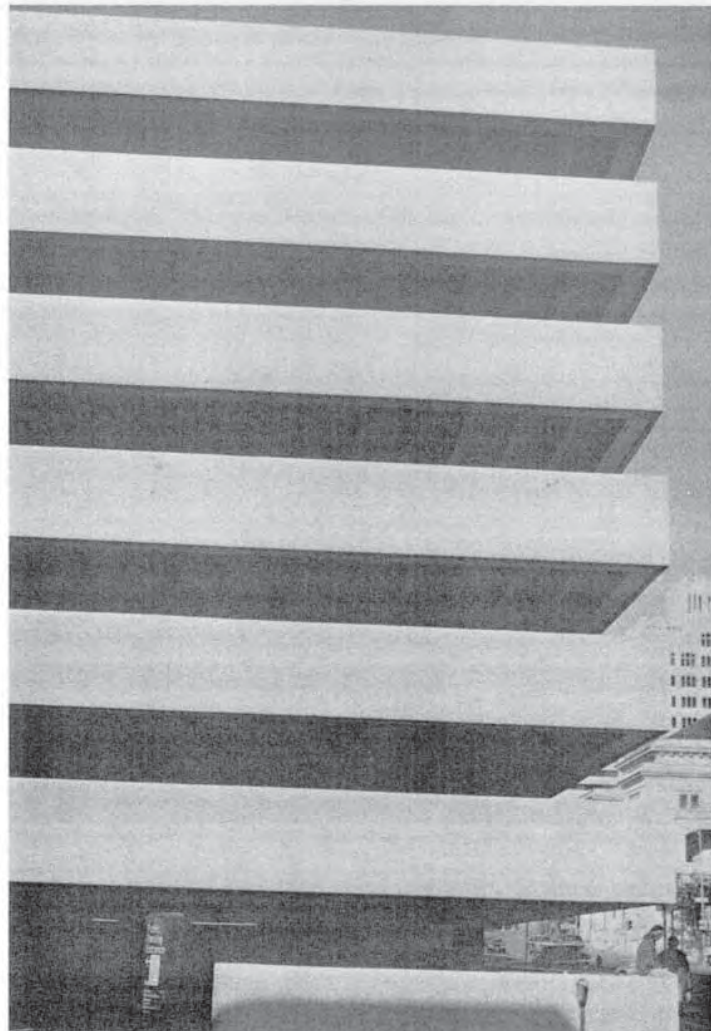
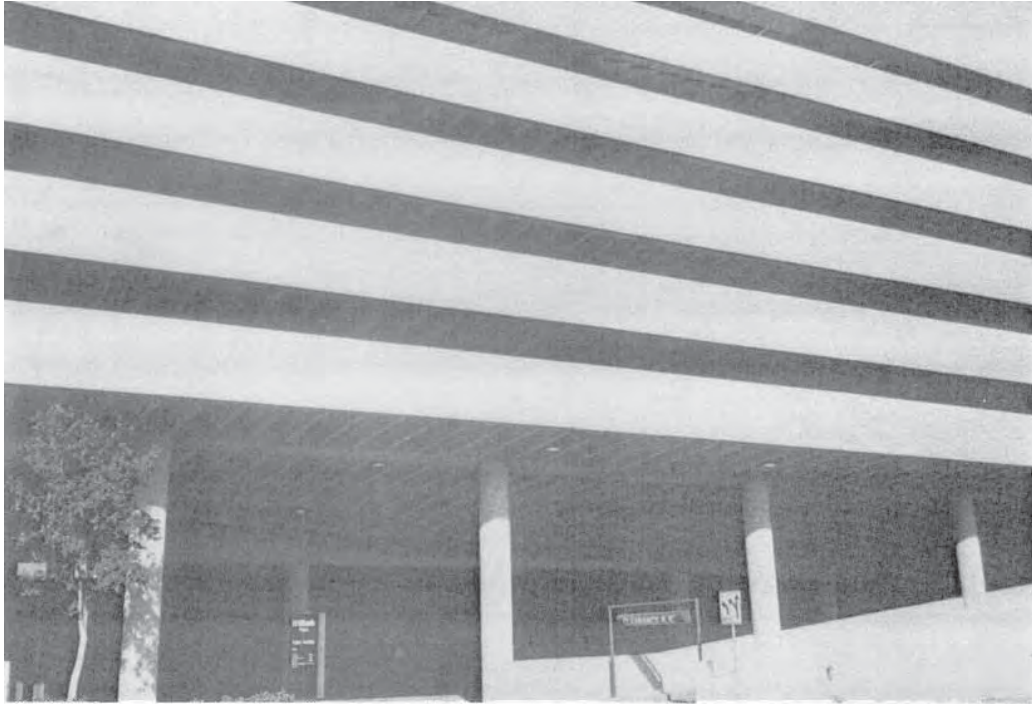

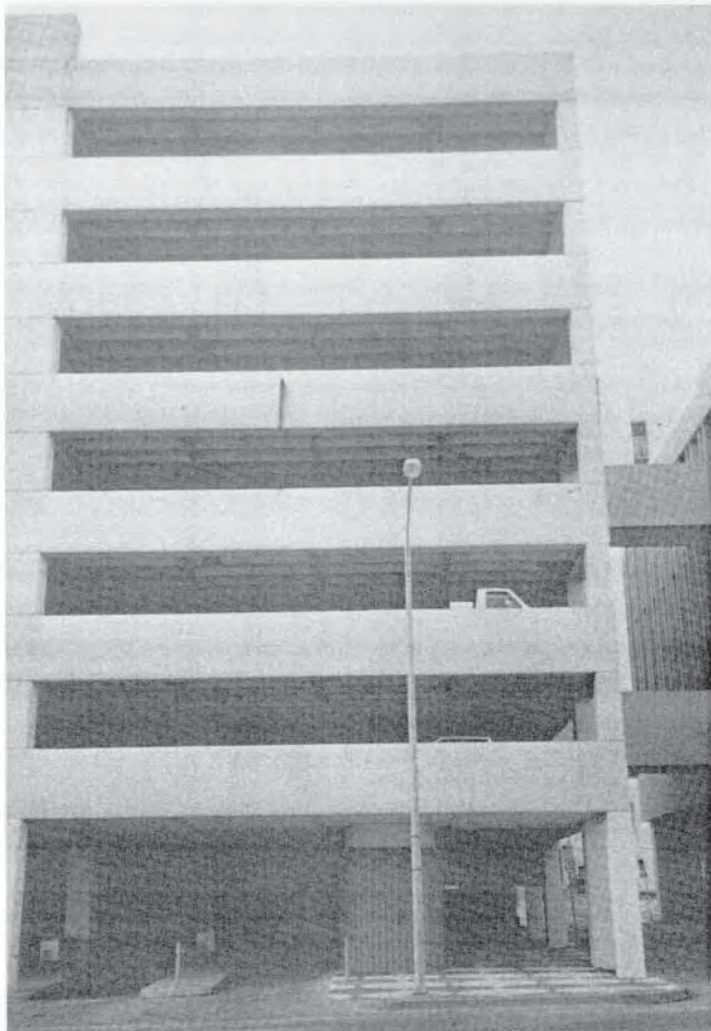
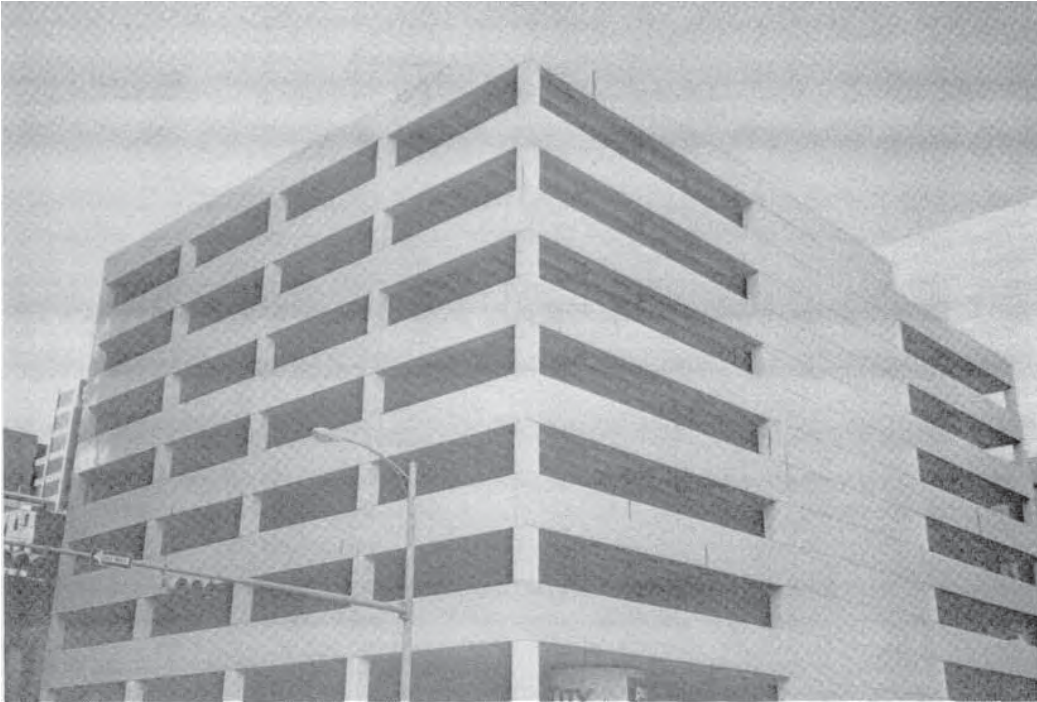

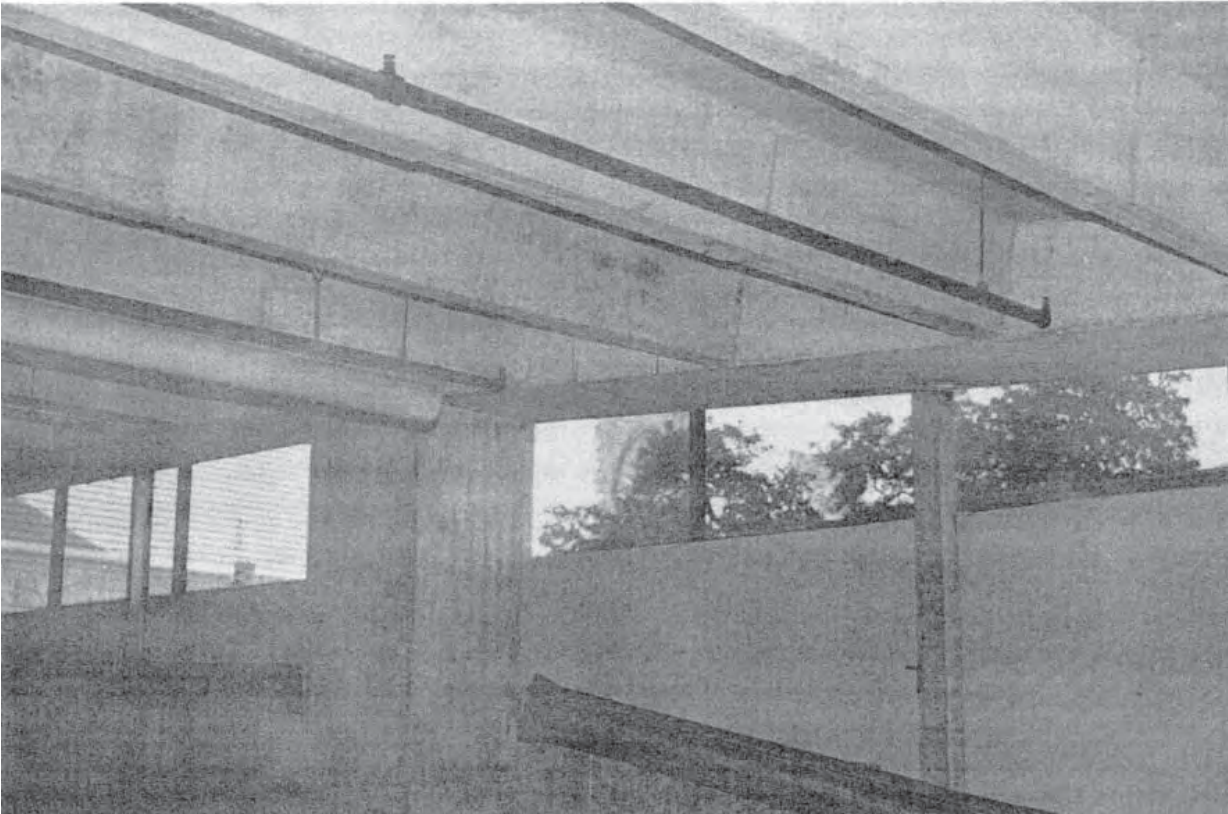
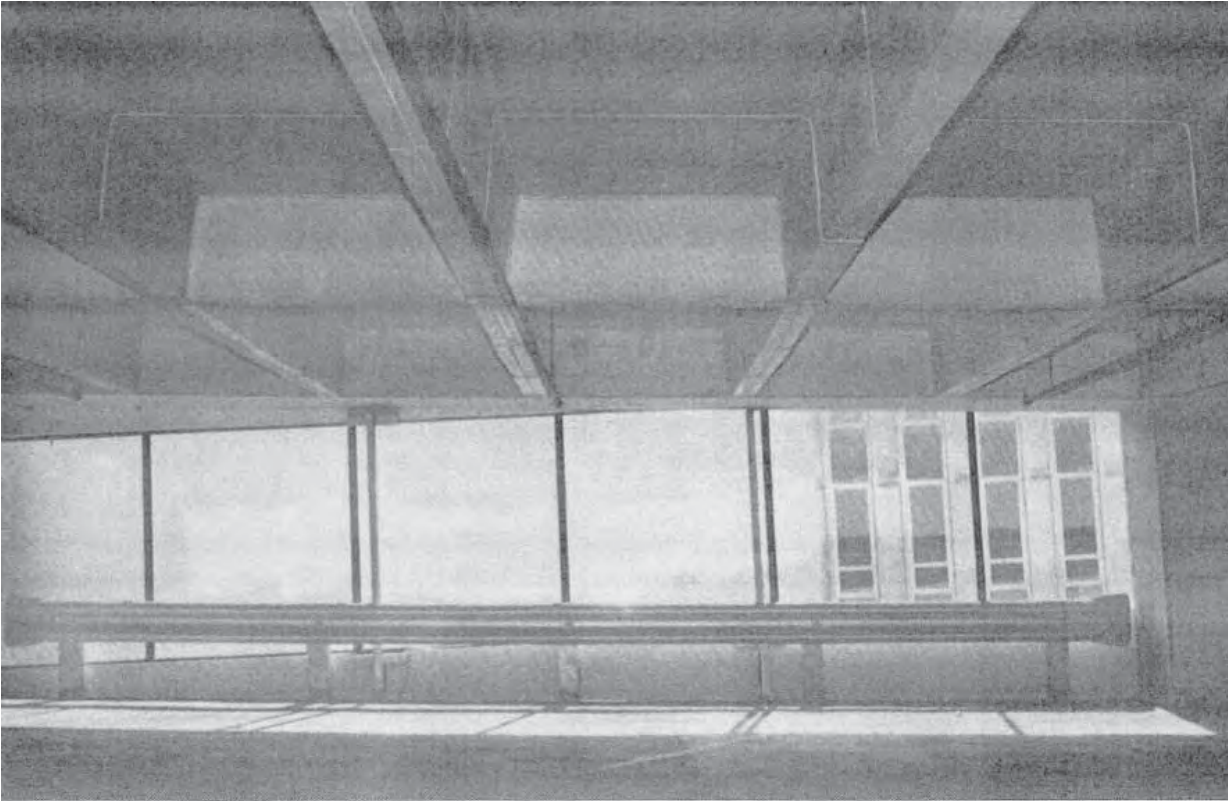

E. KEY SPECIFICATION ITEMS

1. Provide minimum slab compressive stress of 175 psi in both directions.
2. Provide encapsulated tendons in plaxtic sheathing to protect them from moisture and prevent corrosion. Paper wrapped tendons are no longer used and are unacceptable.
3. Provide more than code minimum concrete cover over tendons and reinforcing. Preferably use 1 1/2" clear to steel at top of slabs and 2 1/2" or 2 1/2 x bar diameter clear to main steel and tendons at top of beams (2" minimum cover to stirrups).
4. Provide 5% to 7% of air entrainment in the concrete mix to reduce surface scaling and flaking. Admixture must conform to ASTM C 260.
5. Use 5000 psi (minimum) hardrock concrete with 1" aggregate.
6. Limit water/cement ratio to a maximum of 0.40. This provides a higher strength concrete with lower permeability, less shrinkage, and better durability. This mix also produces less bleedwater so finishing can proceed rapidly.
7. Do not trowel the concrete before the bleedwater evaporates. Doing so will reduce the air entrainment in the top surface, which decreases its resistance to scaling and flaking. Early troweling also drives the bleedwater back into the concrete, increasing the water/cement ratio. [7]
8. Grind, clean, and seal all floor construction joints. Use a high quality flexible polyurethane sealant.
9. Use a good quality, urethane-based penetrating sealer on all concrete parking surfaces, except the top level, to prevent water and chloride infiltration. On the top level, a silane-based penetrating sealer should be used. Also, the use of a waterproofing membrane should be considered over any occupied space.
10. Use a proven "T" type expansion joint cover.
11. Conform to the Post-Tensioning Institute's "Specifications for Unbonded Tendons," category "Structures in Corrosive Environments."
12. Use a medium broom or float swirl finish on all surfaces with a slope less than 10%. Avoid a hand troweled finish. Ramps with slopes greater then 10% should receive a raked finish.
13. All admixtures, other than air entrainment, must conform to the requirements of ASTM C 494. Admixtures containing calcium chloride should be prohibited.
14. Due to the low slump produced by limiting water/cement ratio to 0.40, specify that a properly designed superplasticizer be added to concrete mix to improve fluidity.
15. In harsh cold climates, where salt is used for deicing, add to the concrete mix two gallons/cubic yard of calcium nitrite. This is expensive and a reasonable alternate may be found, but conform to local practices as a minimum solution.
16. Water cure the concrete for seven days. This will greatly enhance the durability of the concrete. Alternate curing compound solutions must be equal in quality to water curing, be applied immediately, and be properly maintained. CURING COMPOUND MUST BE COMPATIBLE WITH SEALER.
17. Microsilica (or "silica fume"), when used in conjunction with superplasticizer produces a denser, higher strength concrete with greatly reduced permeability. It is not widely used at this time, but is gaining acceptance and should be considered.

F. DISCUSSION OF PROBLEMS AND PROPOSED SOLUTIONS

The following is a list of problems frequently encountered in garage design and construction, along with corresponding solutions to these problems. This document should be reviewed by the contractor and subcontractors. It emphasizes items which are not acceptable construction practice

1. FABRICATION AND ERECTION TOLERANCES

Problem	Proposed Solution
a. Tendons arrive at jobsite with sheathing too thin, out-of-round, torn, or with exposed rusting cable.	Contractor should ensure that tendons have a plastic sheathing a minimum of 40 mils thick and that this sheathing is not damaged or the cable exposed during shipping, storage, and placement.
b. Strands not placed within specified dimensional tolerance.	Testing laboratory must review placement and enforce corrective procedures before concrete is cast.
c. Final measured elongation not within 7% ± of design elongation.	Contractor should restress tendons not within tolerances or determine the reason for the discrepancy.

2. ENVIRONMENT RELATED PROBLEMS

Problem	Proposed Solution
a. Failure to account for expansion and contraction over range of temperature experienced.	<p>For buildings longer than 250 ft in one direction, consider adding pour strips. For buildings longer than 300 ft, provide expansion joints. Design expansion joint for movement caused by a 100 degree variation in temperature (minimum) or higher if local conditions dictate. The top deck is subjected to direct sunlight and/or ice and should be designed for an additional 30 degrees variation. This extra temperature movement in top deck will add stress to the top column tier.</p> <p>Design expansion joints for movement caused by a 100 degree variation in temperature, minimum, or higher if local conditions dictate. Top deck is subjected to both ice and sunlight and should be designed for 30 degrees higher variation in temperature. This produces stresses in the top story columns.</p>
b. Poor selection and location of expansion joints.	Use “T” type expansion joint. Thicken slab at expansion joint to direct water away from joint when it occurs at a level or low area. Keep joint clean and free to move. Locate expansion joint at high point of floor slope.
c. Cracking and associated problems.	Cracking problem is substantially less than with topped precast. Constant prestress forces tends to prevent cracks and close up existing cracks.

- d. Shrinkage cracking and flexural cracking under imposed loads.

1) Provide minimum post-tensioning force of 175 psi in slab in both directions. Minimum post-tensioning force should not drop below 125 psi when considering temperature, shrinkage, and restraints 2) Design slab and joists to have zero tension under realistic service loads (dead load plus 25 psf live load) with live load applied on all spans or on alternate (skip) spans, whichever produces the highest stress condition 3) Use a low water/cement ratio of 0.40, with a slump of 2” to 3” and 1” maximum aggregate size 4) Follow ACI recommended concrete placement methods and 5) Provide proper curing with wet burlap for seven days or with curing compound.

- e. Corrosion of reinforcement and anchorage assemblies.

Problem is minimized due to substantially reduced cracking; however 1) At construction and expansion joints, take special care to ensure waterproofing of the joint to protect anchorages. Construction joints should be provided with a formed kerf to be filled with sealant 2) Live ends of cable should not, if possible, be terminated at an expansion joint 3) Provide adequate clear cover over all post-tensioned cables and mild steel. Use 1 1/2” clear at top of slabs and 2 1/2” or 2 1/2 x bar diameter clear to main steel and tendons at top of beams (2” minimum cover to stirrups). THIS MAY BE THE MOST IMPORTANT PRINCIPLE TO ADHERE TO FOR CORROSION PROTECTION 4) In climates where salt is used for deicing, epoxy coat all mild reinforcement within the top 2 1/2” of the concrete slab, including support bars for top slab reinforcement. Epoxy coat bottom reinforcement at all mild reinforced pour strips 5) Apply a penetrating sealer to all levels of the garage 6) Provide a minimum 1/8” per foot slope to drain and 7) specify encapsulated tendons.

- f. Tendon anchors rust, causing concrete staining and spalling.

1) Recess anchors a minimum of 1 1/2”. Apply bonding agent to pocket and fill with non-shrink grout to waterproof anchors. This must be done within 15 days after removing tails 2) Do not place anchors near drains or in planter boxes 3) Couplers can be enclosed in housings and filled with grease 4) In climates where salt is used for deicing, epoxy coat all post-tensioning anchorages after tendons are stressed and tails are cut. 5) Specify encapsulated tendons.

3. CONSTRUCTION RELATED PROBLEMS

Problem	Proposed Solution
a. Improper cover or drape.	Testing laboratory must review placement and enforce corrective procedures before concrete is cast.
b. Tear in tendon sheathing or sheathing is stripped back at anchors.	Use two layers of polyethylene tape to repair any tears in sheathing and to wrap tendon tight to all anchorages.

- c. Tendon kinked at openings, conduit, or mild steel. Displacement due to foot traffic during concrete pour can cause slab spall when cable is stressed. Contractor and testing laboratory must monitor tendon and concrete placement.
- d. Tendon breaks during stressing operation or actual elongation does not agree with anticipated elongation. Provide sufficient capacity in design so that there is reserve capacity to compensate for a small error. Review stressing records for information required. Have coordination meetings with the testing laboratory.
- e. Extreme congestion of tendons in major beams and at column intersections. Provide ample member size and limit stress in beams to 500 psi maximum. Review beam to column anchorage details on shop drawings.
- f. Tendon blows out of concrete as it is being stressed.
 - 1) Avoid sudden reverse drapes in the tendon. Draping in tendons should be gradual and match the dimensions shown on the shop drawings
 - 2) Ensure adequate cover over the tendons
 - 3) Discard pump priming grout from the pumping hose. This grout creates a weak area in the pour
 - 4) Do not allow concrete to be dropped directly on top of a tendon. The weight of the concrete can knock it out of alignment and
 - 5) Provide proper support of tendons with the necessary height and spacing of chairs.

4. DESIGN RELATED PROBLEMS

Problem

Proposed Solution

-
- a. Failure to recognize congestion at beam to column junctures. It is important that the designer recognize and plan for congested areas. He must be familiar with anchor systems and sizes.
 - b. Concrete spalls off bottom of beam or joist below tendons due to tendons being placed solidly across the beam or joist. Detail tendons to be bundled or stacked vertically which allows concrete to fall down the middle of the beam to the bottom of the form. The bottom concrete cover must be adequately tied into the rest of the beam.
 - c. Excessive deflection. Select post-tensioned joist depth for a maximum span-to-depth ratio of 32 for simple spans.
 - d. Stressing problems due to offset in floor levels at ramps. Detail construction joints in joists, beams, and columns. Detail anchorage locations. Be familiar with anchor sizes and required ram clearances.

Examples

 - 1) Access for stressing ram
 - 2) Construction joints between bays
 - 3) Column construction joints
 - 4) Congestion
 - e. Anchor pockets conflict with vertical column reinforcing. Loss of column strength due to pockets required for anchors. Detail vertical reinforcing at pockets and design column based on this bar arrangement and reduced column section.

- | | |
|---|---|
| f. Cracks occur at restraining walls and columns. Construction joints open up. | Locate restraining elements near center of structure. Use pour strips along walls not centrally located. Rigid elements which are not centrally located should be permanently separated. Detail clearly on the drawings. Evaluate and note pouring and stressing sequences on the drawings. |
| g. Column cracking. | Design columns for extra forces due to post-tensioning and thermal stresses. Add ties in ramp columns where floors offset. Add rebar in tops of columns for continuity moments. |
| h. Interior columns at ramps difficult to cast with higher strength concrete due to short sections. | Design interior columns at ramps with same strength concrete as floor. It is not practical to cast short sections of concrete columns with a higher strength concrete than is used on the floor. |

5. MAINTENANCE RELATED PROBLEMS

Problem	Proposed Solution
a. Failure to 1) Keep drain lines clean 2) Repair leaks 3) Replace sealer on concrete decks and sealant in joints 4) Clean expansion joints of dirt and debris 5) Clean and paint rusting embedded plates 6) Report and repair cracked members 7) Clean and repair spalled areas 8) Identify and repair areas which pond water.	Establish and maintain regularly scheduled maintenance. Items 1 through 8 should be included on a checklist. See Section G - "Maintenance Requirements.
b. Premature failure of sealer, sealants, or waterproofing due to incorrect installation or at insufficient rates.	Avoid by having a technical representative of the supplier on the jobsite to affirm, in writing, that the product was used correctly. [5]

G. MAINTENANCE REQUIREMENTS

The most important factor in extending the life of a parking structure is a regular maintenance program. Regular maintenance programs should include the following items

Cracks - When water enters cracks it can work its way to the reinforcing. Corrosion of the reinforcing causes expansion in the concrete, resulting in spalling and loss of reinforcing strength. Cracks should be filled with epoxy or sealant to seal out the water as soon as possible.

Surface Patches - Sawcut 1/2" deep around the damaged concrete. Chip out, clean, and fill with non-shrink, high strength patching mortar.

Drains - Drains should be checked after heavy rains for leaks and clogging. A clogged drain can create ponding on the deck, leading to slab deterioration.

Ponding - Ponded water will cause rapid deterioration of the waterproofing material and then penetrate the concrete. The result will be the same as described for cracks. Ponding is usually caused by faulty drains, concrete irregularities, formwork settlement, or poor design. The specifications should call for the deck drainage to be tested for ponding by the Contractor before he leaves the project. The Architect/Engineer can recommend solutions for problem areas.

DATUM ENGINEERS, INC.

Cleaning - Cleaning should include a regular sweeping (preferably once a month) and a wash down once or twice a year. [6] As a minimum, decks in harsh cold climates, where deicing salt is used, must be thoroughly washed down every spring to eliminate salt residue.

Waterproofing - Clean and reapply penetrating sealer to slabs every five to 10 years. If the surface is extremely dirty, water blast or shot blast preparation might be required. In northern climates, reapply sealer every two to three years.

Expansion Joints - Replace worn or deteriorated expansion joint seals.

Inspection - Garages should be inspected every two to three years. Regular inspections can detect problems before they become major, costly repair jobs.

H. COST ESTIMATE

Construction Estimate The construction quantities tabulated below are based on the area of 1/4 of a typical floor of the garage shown in Part D of this chapter. These could be used for comparative cost of structural construction and waterproofing. Other items such as plumbing, lighting, striping, stairs, foundation, elevators, etc., would be similar in cost for all six systems and, therefore, are not included herein. General conditions, overhead and profit are also not included. For sealer **quantities** listed below, refer to the cost estimate for the “Topped Precast Concrete” system (Chapter 3) for assumptions.

DESCRIPTION	QUANTITY	UNIT
ALL FORMWORK (PANS, BEAMS, AND COLUMNS)	14,500	S.F.
CONCRETE	440	C.Y.
REINFORCING	25.5	TON
POST-TENSIONING	15,000	LB.
ARCHITECTURAL P/C PANEL	256	L.F.
CABLE RAILS	1,600	LB.
SEALERS (AVERAGE)	14,500	S.F.
SEALANT (AT PERIM. OF TOP LEVEL ONLY - AVERAGE PER FLOOR)	51	L.F.

AREA ESTIMATED. 14,500 S.F.

Maintenance Estimate Maintenance quantities tabulated below are based on the area of 1/4 of a typical floor of the garage shown in Part D of this chapter. These could be used for comparative cost of maintenance items related to this particular system. Other items such as sweeping, wash downs, drain cleaning, restriping, etc., would be similar in cost for all six systems and, therefore, are not included herein.

DESCRIPTION	QUANTITY	UNIT
REPLACE SEALANT (AT PERIM. OF TOP LEVEL ONLY - AVERAGE PER FLOOR)	51	L.F.
REPLACE SEALERS (AVERAGE)	14,500	S.F.

AREA ESTIMATED. 14,500 S.F.



Precast Frame with Formed Slab 7

CHAPTER 7

PRECAST FRAME WITH FORMED SLAB

A. DESCRIPTION

Post-tensioned, cast-in-place formed slab on a framework of precast concrete beams and columns. Slabs are normally 5" to 7 1/2" thick. Precast beams and columns are spaced 25'-6" to 30'-0" feet on center. Slab forms are typically hung from the beams so slab shoring is eliminated. Beams might or might not be shored.

B. ADVANTAGES

Rapid Construction - Erection of precast beam and column framework is fast. With a uniform beam spacing, slab formwork can be prefabricated and flown from floor to floor. Total construction time is less than with an all cast-in-place system.

Economical - Beams and columns are mass produced at precast plant under controlled conditions. Slab formwork can be prefabricated and reused. Shoring is not required.

Appearance - Architectural finishes are more consistent on the exposed members (spandrels and columns) because they are precast. Post-tensioning provides for crack-free construction in the slab.

Durability - Since precast members typically use higher strength concrete, the framework members will have a more durable finish. The slab will be post-tensioned, keeping cracks closed or preventing them from forming. There should be less surface flaking and more durability to freeze/thaw cycles. Also, the need for control joints is eliminated.

Fewer Joints - Since deck is cast-in-place and post-tensioned, few joints are required, reducing the need for joint sealants.

Low Maintenance - No painting required. Very little joint sealant to replace. Watertight throughout. A post-tensioned slab reduces the need for waterproofing membranes and the maintenance of the waterproofing.

Lighting - Lighting is often easier to design and detail. It can cover a larger area than with tee or joist systems because of the openness created by increased beam spacing.

C. DISADVANTAGES

Less Functional - Precast framework allows less flexibility for complex shapes, irregular sites, and curved ramps. However, since slabs are formed, this system it is more flexible than an all-precast system.

Connections - Connections of precast members must be detailed for erection tolerances.

Tolerances - Fabrication and erection of precast frame must be accomplished within prescribed tolerances.

Erection Problems - There are problems that arise during erection due to out-of-tolerance fabrication and erection. Also, there are problems due to poor erection practices. These include pad misplacement, rotation of member on pads, point bearing, edges spalling, and improper bracing.

Construction Time - Forming, reinforcing, concrete placement, stressing, and form removal may cause increased construction time over topped and untopped precast systems.

Design Problems - Long term volume changes, due to creep and shrinkage, are high and must be accounted for in design. Pour strips must be provided along rigid walls when they are not centrally located.

Tendon Blowout - If tendons are not placed properly with the specified drape and edge distances, the tendons can create tension in the concrete and blow out. This also happens where weak concrete or pump priming grout is cast around a tendon.

D. **RECOMMENDED
DETAILS**

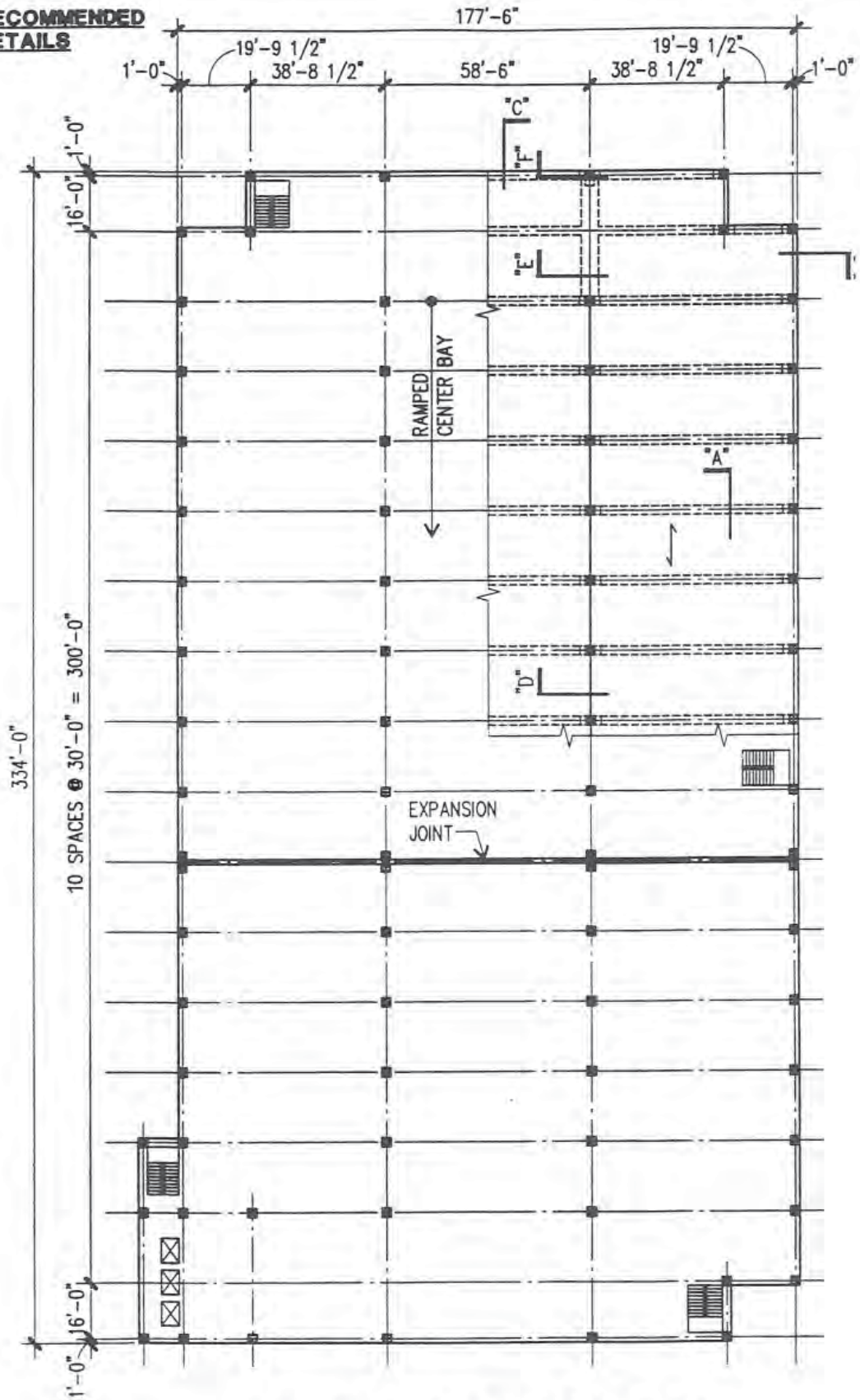

TYPICAL FLOOR FRAMING PLAN

1"=40'-0"

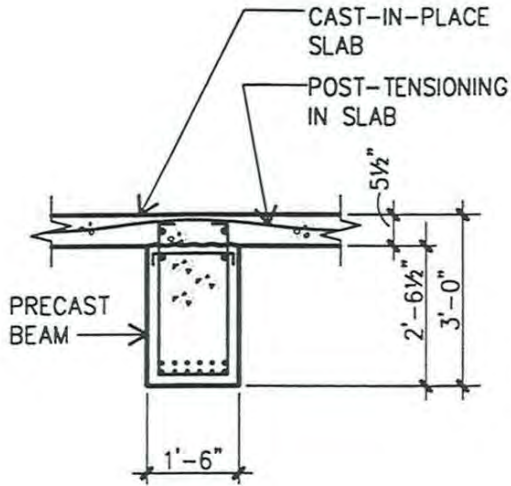

A TYPICAL PRECAST BEAM

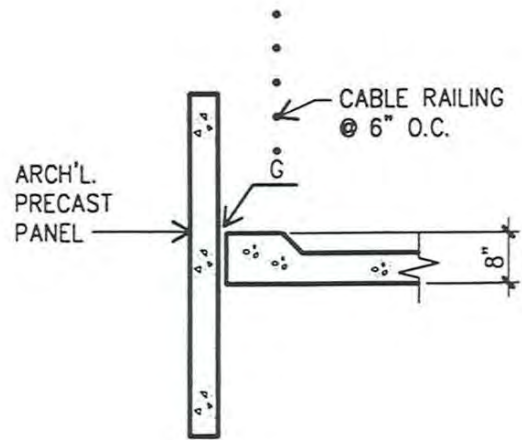

B

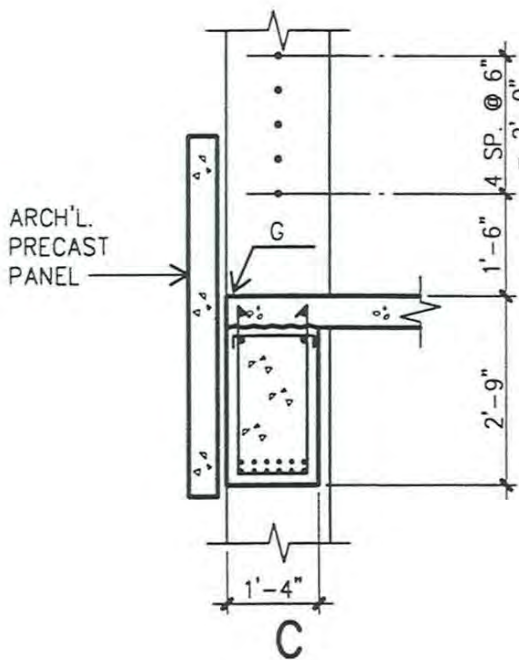

C

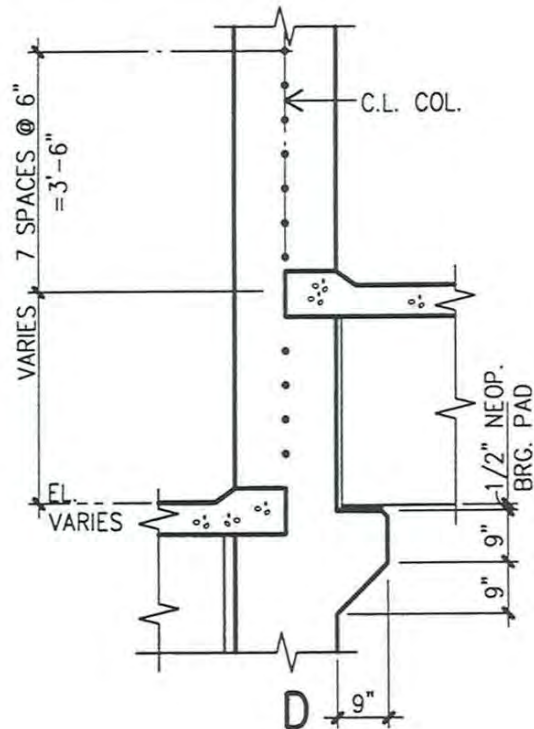

D

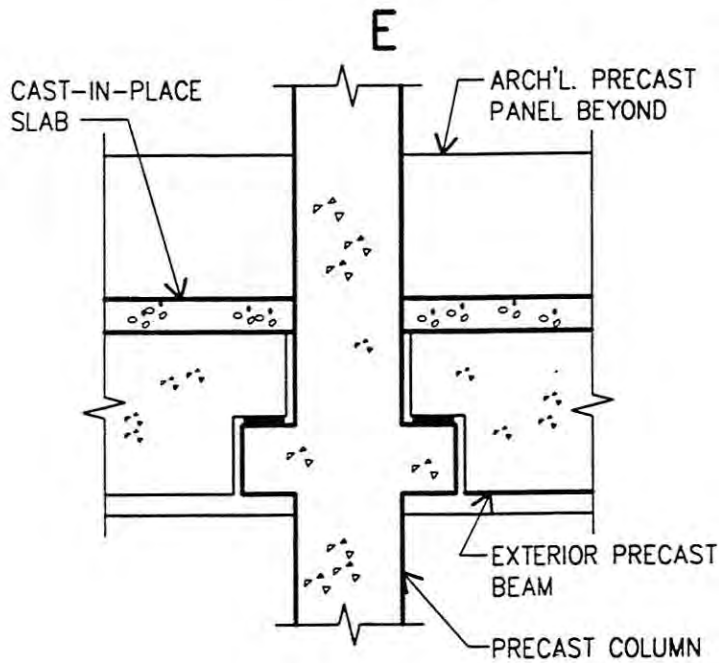
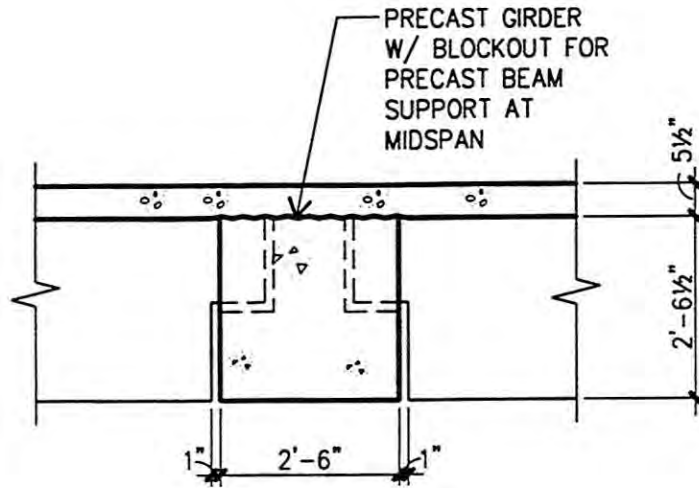

F

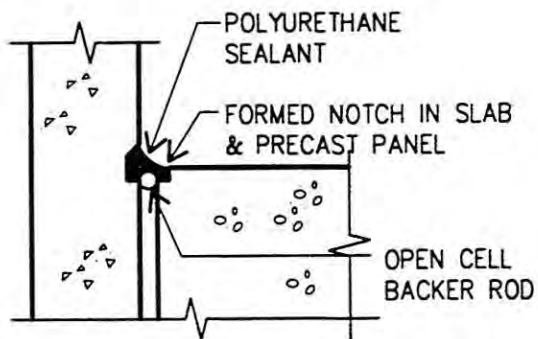

G ROOF LEVEL ONLY

E. KEY SPECIFICATION ITEMS

1. Provide minimum slab compressive stress of 175 psi in direction of slab span.
2. Provide plastic sheathing around all tendons to protect them from moisture and prevent corrosion. Paper wrapped tendons are no longer used and are unacceptable.
3. Provide more than code minimum concrete cover over all tendons and reinforcing. Minimum code requirement at the top of slab is 1", but 1 1/2" should be specified.
4. Provide 5% to 7% of air entrainment in concrete slab mix and 4% to 6% in the precast to reduce surface scaling and flaking. Admixture to conform to ASTM C 260.
5. Limit water/cement ratio to 0.40. This provides higher strength concrete with lower permeability, less shrinkage, and better durability. This mix also produces less bleedwater so finishing can proceed rapidly.
6. Grind, clean, and seal construction joints. Use a high quality flexible polyurethane sealant.
7. All bearing conditions have bearing pads. Bearing pads must meet AASHTO specifications (Division II, Section 25).
8. Embedded metal assemblies should be hot-dip galvanized. Welds on galvanized metal must be protected with field-applied cold galvanizing compound.
9. Use 5000 psi hardrock concrete, with 1" aggregate for cast-in-place slabs, and 5000 psi for precast beams.
10. Use a quality urethane-based penetrating sealer on all concrete parking surfaces, except the top level, to prevent water and chloride infiltration. On top level, a silane-based penetrating sealer should be used. The use of a waterproofing membrane should be considered over any occupied space.
11. Use a proven "T" type expansion joint cover.
12. Do not trowel the concrete slab before the bleedwater evaporates. Doing so will reduce the air entrainment in the top surface. Early troweling also drives the water back into the concrete, increasing the water/cement ratio. [7]
13. Conform to the Post-Tensioning Institutes "Specifications for Unbonded Tendons," category "Structures in Corrosive Environments."
14. Steam or moist cure the precast members in the plant, per ACI 318.
15. Use an upturned thickened edge on slabs without edge beams, this increases stiffness to help prevent sagging at the edge. It also simplifies anchor placement and creates a gutter edge to prevent rainwater from running over the edge of the slab.
16. Use medium broom or float swirl finish on surfaces with a slope less than 10%. Avoid a hand troweled finish. Ramps with slopes greater than 10% should receive a raked finish.
17. All admixtures, other than air entrainment, must conform to requirements of ASTM C 494. Admixtures containing calcium chloride should be prohibited.
18. Due to low slump produced by limiting the water/cement ration to 0.40, specify that a properly designed superplasticizer be added to concrete mix to improve fluidity.
19. In climates where salt is used for deicing, add to the concrete mix two gallons/cubic yard of calcium nitrite. This is expensive and a reasonable alternate may be found, but conform to local practices as a minimum solution.

- 20. Water cure concrete for seven days. This enhances durability of concrete. Alternate curing compound solutions must be equal in quality to water curing, applied immediately, and be properly maintained. CURING COMPOUND MUST BE COMPATIBLE WITH SEALER.
- 21. Microsilica (or “silica fume”), used in conjunction with a superplasticizer, produces a denser, higher strength concrete with greatly reduced permeability. Though not widely used at this time, it is gaining acceptance and should be considered.

F. DISCUSSION OF PROBLEMS AND PROPOSED SOLUTIONS

The following is a list of problems frequently encountered in garage design and construction, along with corresponding solutions to these problems. This document should be reviewed by the contractor and subcontractors. It emphasizes items which are not acceptable construction practices.

1. FABRICATION AND ERECTION TOLERANCES

Problem	Proposed Solution
a. Sloped or point bearing of beams.	Use tapered galvanized steel shim or tapered bearing pad to provide uniform bearing. Tack weld steel shim to confinement plate to avoid its sliding out of place.
b. Mislocated weld plates.	Engineer to review each case individually. May require larger connection members or expansion bolted plates.
c. Mislocated anchor bolts for precast columns.	Require surveyor to locate center line of columns. Use templates to locate bolts. A good start on erection can eliminate many tolerance problems.
d. Cracked or damaged members due to stresses induced during transportation or lifting.	Repair or replace. Submit repair procedure to Engineer for approval. Pressure injection of epoxy grout is normal repair procedure, but should only be done with Engineer’s approval. This is not a magic cure for all problems.
e. Mislocated bearing pad extends beyond ledge.	Not acceptable. Emphasize early to erector and correct out-of-tolerance pads before topping is cast. Bearing pads extending beyond edge of the supporting ledge will inevitably cause spalling of the ledge.
f. Insufficient beam to column bearing.	Not acceptable. Recognize at placement and resolve.
g. Excessively high steel shim stacks and rusting of shim stacks.	Use prefabricated, galvanized steel shims of same size as bearing pad. Align all shims and pads. Alternate steel with neoprene pads. Do not use plastic shims.
h. Cracking and spalling due to inadequate clearance between the end of a member and an abutting vertical surface. [6]	Recognize problem during erection of member. Replace member of incorrect length. End of member may be sawn off if feasible, but do not chip off end. Realign supporting members. Contractor to clean out all debris and concrete in the joint.
i. Tendons arrive at jobsite with sheathing too thin, out-of-round, torn, or with exposed, rusted cable.	Contractor to ensure that tendons have a plastic sheathing a minimum of 40 mils thick and that this sheathing is not damaged or the cable exposed during shipping, storage, and placement.

- j. Tendons not placed within specified dimensional tolerances. Testing laboratory to review placement before concrete is cast.
- k. Final measured elongation not within 7% ± of design elongation. Contractor to restress tendons not within tolerance or determine the reason for the discrepancy.

2. ENVIRONMENT RELATED PROBLEMS

Problem	Proposed Solution
a. Failure to account for expansion and contraction over range of temperature experienced.	<p>For buildings longer than 250 ft in one direction, consider adding pour strips. For buildings longer than 300 ft, provide expansion joints. Design expansion joint for movement caused by a 100 degree variation in temperature (minimum) or higher if local conditions dictate. The top deck is subjected to direct sunlight and/or ice and should be designed for an additional 30 degrees variation. This extra temperature movement in top deck will add stress to the top column tier.</p> <p>Design expansion joint for movement caused by a 100 degree variation in temperature, minimum, or higher if local conditions dictate. Top deck is subjected to both ice and sunlight and should be designed for 30 degrees higher variation in temperature. This will produce stresses in the top story columns.</p>
b. Expansion joint inoperative or leaking.	Use “T” type expansion joint. Build up concrete at expansion joint to direct water away from the joint when it occurs at a level or low area. Keep joint clean and free to move.
c. Cracking and associated problems.	Cracking problem is substantially less with post-tensioning. Constant prestress force tends to prevent cracks and close up existing cracks.
d. Shrinkage cracking and cracking under imposed loads.	<p>1) Provide minimum post-tensioning force of 175 psi in direction of slab span. Minimum post-tensioning force should not drop below 125 psi when considering temperature, shrinkage, and restraints 2) Design slab to have zero tension under realistic service loads (dead load plus 25 psf live load) with live load applied on all spans or on alternate (skip) spans, whichever produces the highest stress condition 3) Use a low water/ cement ratio of 0.40, with a slump of 2” to 3” and 1” maximum aggregate size 4) Follow ACI recommended concrete placement methods and 5) Provide proper curing with wet burlap for 7 seven days or with curing compound.</p>

- e. Corrosion of reinforcement and anchorage due to cracks.

Problem minimized due to substantially reduced cracking; however:
1) At construction and expansion joints special care must be taken to ensure waterproofing of the joint to protect anchorages. Construction joints should be provided with formed kerf to be filled with sealant **2)** Live ends of cable should not, if possible, be terminated at an expansion joint **3)** Provide adequate clear cover over all post-tensioned cables and mild steel. Use 1 1/2" minimum at top of slab. **THIS MAY BE THE MOST IMPORTANT PRINCIPAL TO ADHERE TO FOR CORROSION PROTECTION** **4)** In harsh climates, where salt is used for deicing, epoxy coat all mild reinforcement within top 2 1/2" of slab thickness, including support bars for top slab reinforcement. Epoxy coat bottom reinforcement at all mild reinforced pour strips. **5)** Apply a penetrating sealer to all levels of the garage and **6)** Provide minimum 1/8" per foot slope to drain along slope line. **7)** Specify encapsulated tendons.

- f. Tendon anchors rust causing concrete staining and spalling.

1) Recess anchors a minimum of 2". Apply bonding agent to pocket and fill with non-shrink grout to waterproof anchor. This must be done within 15 days after removing tails **2)** Do not locate anchors near drains or in planter boxes **3)** Couplers can be enclosed in housing and filled with grease and **4)** In harsh cold climates, where salt is used for deicing, epoxy coat post-tensioning anchors after tendons are stressed and tails are cut. **5)** Specify encapsulated tendons.

3. CONSTRUCTION RELATED PROBLEMS

Problem	Proposed Solution
a. Mislocated anchor bolts.	See Item 1.c.
b. Inadequate air entrainment.	Conform to Specifications: 5% ± for precast, 6% +/- for cast-in-place.
c. Insufficient construction bracing.	Precaster to prepare erection plans for contractor's and erector's use.
d. Failure to grout base plate after column or wall is plumbed. Placing floors above may cause local failure of concrete.	Contractor and testing laboratory to monitor.
e. Improper placement of bearing pads.	See Item 1.e.
f. Failure of cold galvanize welded connections.	Contractor and testing laboratory to monitor.
g. Scheduling: Pieces damaged in transit or erection may have to be recast and thereby cause delays or redirection of erection.	Contractor/Architect to review individual cases. Contractor to submit repair to Architect/Engineer for approval. Generally, patches lead to premature deterioration. Sealed cracks should not be accepted without a thorough review of the long term effects.
h. Improper cover or drape.	Testing laboratory to approve placement before concrete is cast.

- | | |
|---|---|
| i. Tear in cable sheathing or sheathing is stripped back at anchors. | Use two layers of polyethylene tape to repair any tears in sheathing and to wrap cable tight to all anchorages. |
| j. Cable kinked at openings, conduit, or mild steel. Displacement due to foot traffic during concrete pour can cause slab spall when cable is stressed. | Problem can be avoided by monitoring placement of strand by the contractor/testing laboratory. |
| k. Cable breaks during stressing operation or cable elongation does not agree with anticipated elongation. | Provide sufficient capacity in design so that there is reserve capacity to compensate for a small error. Review stressing records for information required. Have coordination meetings with testing laboratory. |
| l. Tendon blows out of concrete as it is being stressed. | 1) Avoid sudden reverse drapes in tendon. Draping in tendons should be gradual and match dimensions on shop drawings 2) Ensure adequate cover over tendons and 3) Discard pump priming grout from the pumping hose. This grout creates a weak area in the slab. |
| m. Concrete cracks where embeds are welded together. | This is caused by expansion of the embed due to the heat of welding. Use intermittent welds or cool plate during welding. |

4. DESIGN RELATED PROBLEMS

Problem

Proposed Solution

- | | |
|--|---|
| a. Competitive precast bid: Precasters want to bid project based on use of their standard formwork (column size, haunch size, beam width,) and details. These generally do not conform exactly to the drawings and specifications. This makes comparison of bids difficult and creates a period of negotiation after a precaster is chosen. In the negotiation phase all discrepancies are resolved but in many cases lesser solutions are accepted by an owner because the precaster offers economic incentives to use his standard system. | The drawings should state that the base bid for the job should conform exactly to the drawings and specifications. All deviations from the details and specification as proposed by the contractor should be itemized and submitted as deduct alternates. The economic benefits can then be compared to the reduction in long term quality. |
| b. Division of design: Precaster typically designs members. There is a cost incentive to design members as close as possible to minimum code allowables. However, there are cases where engineering judgement should dictate an alternate design or an increase over code minimum design. | Engineer of record should identify any areas of concern and provide design or limitations of design on contract documents. Example: design of corbel, maximum allowable tensile stress in pretensioned members, and areas to be designed for increased loads. |

- | | |
|--|---|
| c. Insufficient bearing due to a member being skewed in plan. | Detail extra bearing length. The end of the member will need to be cast with a skew to maximize bearing length. |
| d. Concrete cracks at embedded metals where members are welded together. | Avoid welding precast members together when possible. If welding must be done use an angle connector and reinforce around embeds. |
| e. Excessive deflections. | Select post-tensioned slab thickness based on a maximum span-to-depth ratio of 45. Select composite beam depth for a maximum ratio of 28 if shored. |
| f. Cracks occur at restraining walls and columns. Construction joints open up. | Locate restraining elements near center of structure. Use pour strips along walls not centrally located. Detail clearly on drawings. Evaluate and note pouring and stressing sequences on drawings. |
| g. Stressing problems due to offset in floor levels at ramps. Examples: Access to stressing area and construction joints between bays. | Recognize ramp divergence from flat floor as a problem area. Detail construction joints in slabs. Detail anchorage locations. Be familiar with anchor sizes and required ram clearances. |

5. MAINTENANCE RELATED PROBLEMS

Problem	Proposed Solution
a. Failure to: 1) Keep drain lines clean 2) Repair leaks 3) Replace sealer on concrete decks and sealant in joints 4) Clean expansion joints of dirt and debris 5) Clean and paint rusting embedded plates 6) Report and repair cracked members 7) Clean and repair spalled areas and 8) Identify and repair areas which pond water.	Establish and maintain regularly scheduled maintenance. Items 1 through 8 should be included on a checklist. See Section G - "Maintenance Requirements."
b. Premature failure of sealers, sealants, or waterproofing due to being installed incorrectly or at insufficient rates.	Avoid by having a technical representative of the supplier on the jobsite and to affirm, in writing, that the product was used correctly. [5]

G. MAINTENANCE REQUIREMENTS

The most important factor in extending the life of a parking structure is a regular maintenance program. Regular maintenance programs should include the following items:

Cracks - When water enters cracks, it can contact the reinforcing. Corrosion of reinforcing causes loss of cross-section and expansion in the concrete, creating spalling and loss of reinforcing strength. For this reason, any cracks should be filled with epoxy or sealant to seal out the water.

Drains - Drains should be checked at least every 2 months for leaks and clogging. A clogged drain can create ponding on the deck which leads to slab deterioration.

Embedded Plates - Any steel that shows signs of corrosion should be cleaned and painted. Corrosion can cause rust streaks on the concrete below, as well as lead to possible structural damage if not attended to.

Surface Patches - Sawcut 1/2" deep around the area to be patched. Chip out, clean, apply bonding agent and fill with non-shrink patching mortar.

Ponding - Ponded water causes rapid deterioration of waterproofing material and penetrates the concrete. The result will be the same as described for cracks. Ponding is usually caused by faulty drains, concrete irregularities, formwork settlement, or poor design. The specifications should call for deck drainage to be tested for ponding by the Contractor before he leaves the project. The Architect/Engineer can recommend solutions for problem areas.

Cleaning - Cleaning should include regular sweeping (preferably once a month) and a wash down once or twice a year. [6] As a minimum, decks in harsh cold climates must be thoroughly washed down every spring to eliminate salt residue.

Waterproofing - Clean and reapply penetrating sealer to slabs every five to 10 years. If the surface is extremely dirty, water blast or shot blast preparation might be required. In harsh climates, reapply sealer every two to three years.

Expansion Joints - Replace worn or deteriorated expansion joint seals.

Inspection - Garage should be inspected every two to three years. Regular inspections can detect problems before they become major, costly repair jobs.

H. COST ESTIMATE

Construction Estimate: The construction quantities tabulated below are based on the area of 1/4 of a typical floor of the garage shown in Item D of this chapter. These quantities could be used for comparative cost of structural construction and waterproofing. Other items such as plumbing, lighting, striping, stairs, foundations, etc., would be similar in cost for all six systems and, therefore, are not included herein. General conditions, overhead, and profit have also been excluded. For sealer quantities listed below, refer to the cost estimate for the “Topped Precast Concrete” system (Chapter 3) for assumptions.

DESCRIPTION	QUANTITY	UNIT
SLAB FORMWORK	13,672	S.F.
PRECAST BEAMS	512	L.F.
PRECAST GIRDER	36	L.F.
PRECAST COLUMNS	125	L.F.
CONCRETE	313	C.Y.
REINFORCING	10	TONS
POST-TENSIONING	13,000	LB.
ARCHITECTURAL P/C PANELS	256	L.F.
CABLE RAILS	1,600	LB.
SEALERS (AVERAGE)	14,500	S.F.
SEALANT (AT PERIMETER OF TOP LEVEL ONLY - AVERAGE PER FLOOR)	51	L.F.
AREA ESTIMATED.....		14,500 S.F.

Maintenance Estimates: Maintenance quantities tabulated below are based on the area of 1/4 of a typical floor of the garage shown in Item D of this chapter. These quantities could be used for comparative cost of maintenance items that relate to this particular system. Other items such as sweeping, wash downs, drain cleaning, restriping, etc., would be similar in cost for all six systems and, therefore, are not included herein.

DESCRIPTION	QUANTITY	UNIT
REPLACE SEALANT (AT PERIMETER OF TOP LEVEL ONLY - AVERAGE PER FLOOR)	51	L.F.
REPLACE SEALERS (AVERAGE)	14,500	S.F.
AREA ESTIMATED.....		14,500 S.F.



Steel Frame with Formed Slab 8

CHAPTER 8

STEEL FRAME WITH FORMED SLAB

A. DESCRIPTION

Post-tensioned, cast-in-place formed slab, on a framework of steel beams and columns. The only difference between this system and the “Precast Frame with Formed Slab” system (Chapter 7) is that the structural framework is steel in lieu of precast concrete.

B. ADVANTAGES

Rapid Construction - Erection of steel beam and column framework is fast and easy. With a uniform beam spacing, slab formwork can be prefabricated and flown from floor to floor. Total construction time is less than with an all cast-in-place system.

Economical - All beams and columns are fabricated in the shop. Formwork for slabs can also be prefabricated and easily reused.

Deck Durability - Since the slab will be post-tensioned it will keep cracks closed or prevent them from forming. There should be less surface flaking and more durability to freeze/thaw cycles. Also, the need for control joints is eliminated.

Fewer Joints - Since the deck is cast-in-place and post-tensioned, few joints are required. This also reduces the need for joint sealants and the associated maintenance.

Flexibility - Steel beams can be cambered as desired for drainage. Beams can be warped or have compound slopes. Expansion can be easily accomplished.

Lighting - Lighting is often easier to design and detail. It can cover a larger area than with tee or joist systems because of the openness created by the increased beam spacing.

Lighter Structure - Structure is visibly lighter in appearance. It is also lighter in weight, therefore decreasing foundation size and cost. A lighter structure is a design advantage in seismic zones.

C. DISADVANTAGES

Maintenance - Steel is exposed and may require repainting. If rusting occurs due to paint loss, aesthetic and possibly structural problems will occur.

Appearance - Structure will be exposed steel and concrete combined. If precast exterior panels are used, then three different materials are combined; steel, cast-in-place concrete, and precast concrete.

Less Functional - Steel framework allows less flexibility than cast-in-place concrete for complex shapes, irregular sites, and curved ramps. However, since slabs are formed, this system is more flexible than an all precast structure.

Construction Time - Forming, reinforcing, concrete placement, stressing, and form removal may cause increased construction time over topped and untopped precast systems.

Design Problems - Long term volume changes, due to creep and shrinkage, are high and must be accounted for in design. Pour strips must be provided along rigid walls that are not centrally located.

Less Fire Resistant - Structural steel is less fire resistant than concrete if not fireproofed. Fireproofing is expensive and not practical for open parking structures.

Tendon Blowout - If tendons are not placed properly within specified drape and edge distances, they can create tension in the concrete and blow out. This also happens where weak concrete or pumping grout is cast around the tendon.

D. RECOMMENDED DETAILS

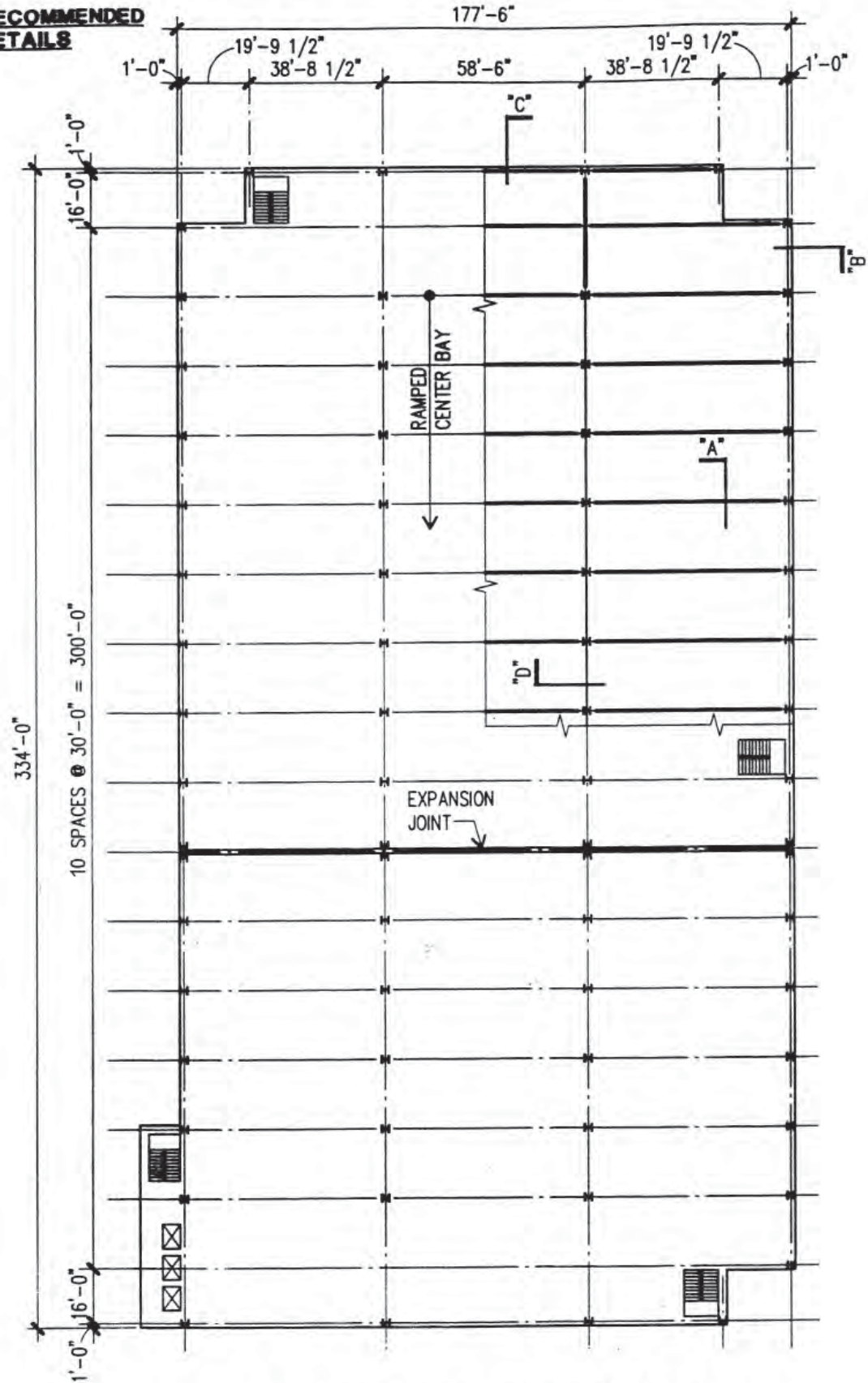

TYPICAL FLOOR FRAMING PLAN
1"=40'-0"

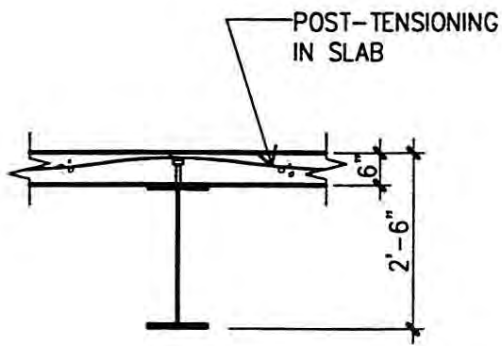

A

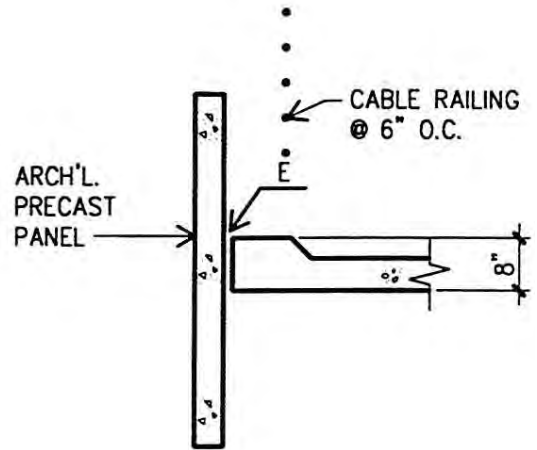

B

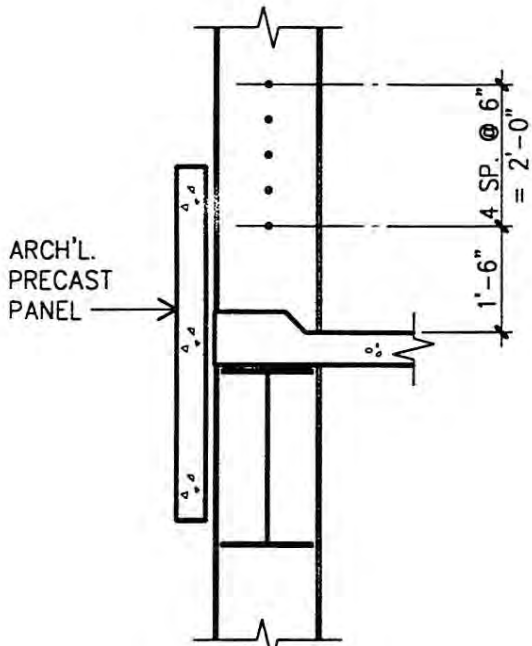

C

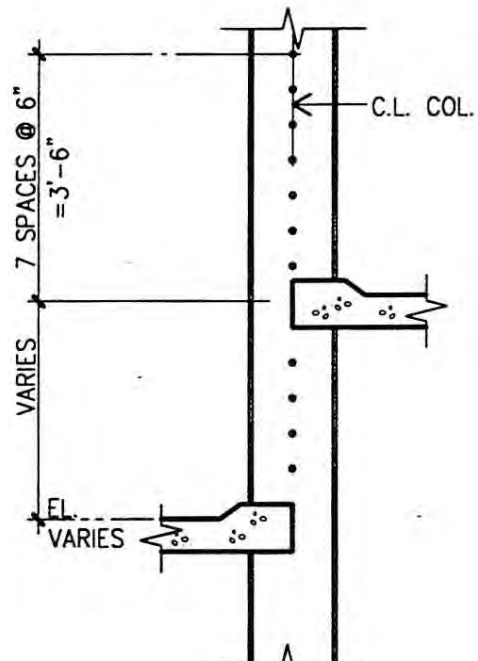

D

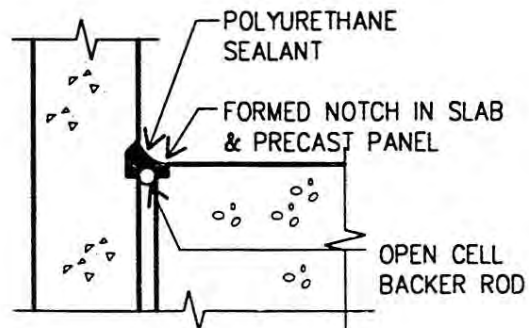

E ROOF LEVEL ONLY

STRUCTURAL STEEL SYSTEM



TEXAS TRIAL LAWYER'S GARAGE

Austin, Texas

169 Cars

Structural steel columns and beams supporting a cast-in-place concrete slab on composite metal deck.





E. KEY SPECIFICATION ITEMS

1. Provide minimum slab compressive stress of 175 psi in direction of slab span.
2. Provide encapsulated tendons with plastic sheathing to protect them from moisture and prevent corrosion. Paper wrapped tendons are no longer used and should never be allowed.
3. Provide more than code minimum concrete cover over all tendons and reinforcing. Minimum code requirement at top of the slab is 1", but 1 1/2" should be specified.
4. Provide 5% to 7% of air entrainment in the concrete slab mix to reduce surface scaling and flaking. Admixture to conform to ASTM C 260.
5. Limit water/cement ratio to a maximum of 0.40 (five gallons/sack of cement). This will provide a higher strength concrete with lower permeability, less shrinkage and better durability. This mix produces less bleedwater so finishing can proceed rapidly.
6. Grind, clean, and seal all construction joints. Use a high quality flexible polyurethane sealant.
7. Steel beams, girders, and columns to be ASTM A 572, Grade 50. All other steel to be ASTM A 36.
8. Welding to be done by American Welding Society certified welders.
9. Shear connectors to be 1" diameter Nelson Studs or equal.
10. Grout for base plates to be pre-mixed, non-metallic, non-shrink, minimum 5000 psi compressive strength at 28 days.
11. Use 5000 psi hardrock concrete with 1" aggregate for slabs.
12. Do not trowel concrete before the bleedwater evaporates. Doing so will reduce the air entrainment in the top surface. Early troweling also drives the water back into the concrete, increasing the water/cement ratio. [7]
13. Use a quality urethane-based penetrating sealer on all concrete parking surfaces, except the top level, to prevent water and chloride infiltration. On the top level, a silane-based penetrating sealer should be used. Also, the use of a waterproofing membrane should be considered over any occupied space.
14. Use a proven "T" type expansion joint cover.
15. Use a two-coat epoxy paint system to protect the steel. Repair any areas damaged in shipment, erection, or deck construction.
16. Conform to the Post-Tensioning Institute's "Specifications for Unbonded Tendons," category "Structures in Corrosive Environments."
17. Provide an upturned thickened edge on slabs without edge beams. This increases stiffness to help prevent visible sagging at the edge. It also simplifies anchor placement and create a gutter edge to prevent rainwater from running over the edge of the slab.
18. Use a medium broom or float swirl finish on surfaces with a slope of less than 10%. Avoid a hand troweled finish. Ramps with slopes greater than 10% should receive a raked finish.
19. All admixtures, other than air entrainment, must conform to requirements of ASTM C 494. Admixtures containing calcium chloride should be prohibited.
20. Due to low slump produced by limiting the water/cement ratio to 0.40, specify a properly designed superplasticizer be added to concrete mix to improve fluidity.
21. In harsh cold climates, where salt is used for deicing, add to the concrete mix two gallons/cubic yard of calcium nitrite. This is expensive and a reasonable alternate may be found, but conform to local practices as a minimum solution.
22. Water cure concrete for seven days. This greatly enhances the durability of the concrete. Alternate curing compound solutions must be; equal in quality to water curing, applied immediately, and properly maintained. CURING COMPOUND MUST BE COMPATIBLE WITH SEALER.

23. Microsilica (or “silica fume”), when used in conjunction with a superplasticizer produces a denser, higher strength concrete with greatly reduced permeability. It is not widely used at this time but is gaining acceptance and should be considered.

F. DISCUSSION OF PROBLEMS AND PROPOSED SOLUTIONS

The following is a list of problems frequently encountered in garage design and construction, along with corresponding solutions to these problems. This document should be reviewed by the contractor and subcontractors. It emphasizes items which are unacceptable construction practices.

1. FABRICATION AND ERECTION TOLERANCES

Problem	Proposed Solution
a. Tendons arrive at jobsite with sheathing too thin, out-of-round, torn or with exposed, rusting cable.	Contractor to ensure that tendons have a plastic sheathing a minimum of 40 mils thick and that this sheathing is not damaged or the cable exposed during shipping, storage, and placement.
b. Tendons not placed within specified dimensional tolerance.	Testing laboratory to approve placement before concrete is cast.
c. Final measured elongation not within 7% ± of design elongation.	Contractor to restress tendons not within tolerances or determine the reason for the discrepancy.
d. Mislocated anchor bolts for steel columns.	Require surveyor to locate center line of columns. Use template to locate bolts. A good start on erection can eliminate many tolerance problems.

2. ENVIRONMENT RELATED PROBLEMS

Problem	Proposed Solution
a. Failure to account for expansion and contraction over the range of temperature experienced.	<p>For buildings longer than 250 ft in one direction, consider adding pour strips. For buildings longer than 300 ft, provide expansion joints. Design expansion joint for movement caused by a 100 degree variation in temperature (minimum) or higher if local conditions dictate. The top deck is subjected to direct sunlight and/or ice and should be designed for an additional 30 degrees variation. This extra temperature movement in top deck will add stress to the top column tier.</p> <p>Design expansion joint for movement caused by a 100 degree variation in temperature, minimum, or higher if local conditions dictate. Top deck is subjected to ice and sunlight and should be designed for a 30 degree higher variation in temperature. This also produces stresses in the top story columns.</p>
b. Poor selection of expansion joint.	Use “T” type expansion joint. Build up concrete to direct water away from expansion joint when joint occurs at a level or low area. Keep joint clean and free moving.
c. Cracking and associated problems.	Cracking problem is substantially less than with topped precast. Constant prestress force tends to prevent cracks and close up existing cracks.

- d. Shrinkage cracking and cracking under imposed loads.

1) Provide minimum post-tensioning force of 175 psi in direction of slab span. Minimum post-tensioning force should not drop below 125 psi when considering temperature, shrinkage, and restraints 2) Design slab for zero tension under realistic service loads (dead load plus 25 psf live load) with live load applied on all spans or alternate (skip) spans, whichever produces the higher stress condition 3) Use a low water/cement ratio of 0.40, with a slump of 2" to 3" and a 1" maximum aggregate size 4) Follow ACI recommended concrete placement methods and 5) Provide proper curing with wet burlap for seven days or with curing compound.

- e. Corrosion of reinforcement and anchorage through cracks.

Problem minimized due to substantially reduced cracking, however:
1) At construction and expansion joints, special care must be taken to ensure waterproofing of the joint to protect anchorages. Construction joints should be provided with formed kerf to be filled with sealant 2) Live ends of cable should not, if possible, be terminated at an expansion joint 3) Provide adequate clear cover over all post-tensioned cables and mild steel. Use 1 1/2" minimum at top of slab. THIS MAY BE THE MOST EFFECTIVE PRINCIPLE TO ADHERE TO FOR CORROSION PROTECTION 4) Apply penetrating sealer to all levels of garage 5) Provide a minimum 1/8" per foot slope to drain 6) In harsh climates, where salt is used for deicing, epoxy coat all reinforcement within top 2 1/2" of the concrete slab, including support bars for top slab reinforcement. Epoxy coat bottom reinforcement at all mild reinforced pour strips and 7) specify encapsulated tendons.

- f. Tendon anchors rust, creating concrete staining and spalling.

1) Recess anchors a minimum of 2". Apply bonding agent to pocket and fill with non-shrink grout to waterproof anchor. This must be done within 15 days after removing tails 2) Do not locate anchors near drains or in planter boxes 3) Couplers can be enclosed in housing and filled with grease and 4) In harsh climates, where salt is used for deicing, epoxy coat all post-tensioning slab anchors after tendons are stressed and tails cut. 5) Specify encapsulated tendons.

3. CONSTRUCTION RELATED PROBLEMS

Problem	Proposed Solution
a. Improper cover or drape.	Testing laboratory to approve placement before concrete is cast.
b. Tear in cable sheathing or sheathing is stripped back at anchors.	Use two layers of polyethylene tape to repair any tears in sheathing and to wrap cable tight to all anchorages.
c. Cable kinked at openings, conduit, or mild steel. Displacement due to foot traffic during concrete pour can cause slab spall when cable is stressed.	Contractor and testing laboratory to monitor cable and concrete placement.
d. Cable breaks during stressing operation or cable elongation does not agree with anticipated elongation.	Provide sufficient capacity in design so there is reserve capacity to compensate for a small error. Review stressing records for information required. Have coordination meetings with testing laboratory.

- e. Tendon blows out of concrete as it is being stressed. 1) Avoid sudden reverse drapes in tendon. Draping in tendons should be gradual and match dimensions on shop drawings 2) Ensure adequate cover over tendons 3) Discard pump priming grout from pumping hose. This grout creates a weak area in slab 4) Do not allow concrete to be dropped directly on top of a tendon. Weight of concrete may knock it out of alignment and 5) Provide proper support of tendons with the necessary height and spacing of chairs.

- f. Scratches and damage to paint on structural steel. All damage to coating on structural steel should be field repaired.

4. DESIGN RELATED PROBLEMS

Problem	Proposed Solution
a. Excessive deflections.	Select post-tensioned slab thickness based on a maximum span to depth ratio of 45. When girders are parallel to direction of post-tensioning, stress in the girder is increased 5% to 10% due to the post-tensioning of the slab.
b. Cracks occur at restraining walls and columns. Construction joints open up.	<u>Locate restraining elements near center of structure. Use pour strips along walls not centrally located. Preferably, rigid elements which are not centrally located should be permanently separated.</u> Detail clearly on drawings. Evaluate and note pouring and stressing sequence on drawings.
c. Stressing problems due to offset in floor levels at ramps. Examples: Access for stressing ram and construction joints between bays.	Recognize ramp divergence from floor as a problem area. Detail construction joints in slabs. Detail anchorage locations. Be familiar with anchor sizes and required ram clearances.

5. MAINTENANCE RELATED PROBLEMS

Problem	Proposed Solution
a. Failure to: 1) Keep drain lines free and clean 2) Repair leaks 3) Replace sealer on concrete deck and sealant in joints 4) Clean expansion joints of dirt and debris 5) Clean and paint rusting steel 6) Report and repair cracks 7) Clean and repair spalled areas, and 8) Identify and repair areas which pond water.	Establish and maintain regularly scheduled maintenance. Items 1 through 8 should be included on a checklist. See Section G - "Maintenance Requirements."
b. Premature failure of sealers, sealants, or waterproofing due to being installed incorrectly or at insufficient rates.	Avoid by having a technical representative of the supplier on the jobsite and to affirm, in writing, that the product was used correctly. [5]

G. MAINTENANCE REQUIREMENTS

The most important factor in extending the life of a parking structure is a regular maintenance program. Regular maintenance programs should include the following items:

Cracks - When water enters cracks, it can contact the reinforcing. Corrosion of reinforcing causes expansion in the concrete, creating spalling and loss of reinforcing strength. For this reason, cracks should be filled with epoxy or sealant to seal out the water.

Surface Patches - Sawcut 1/2" deep around the patch area. Chip out, clean, apply bonding agent, and fill with non-shrink patching mortar.

DATUM ENGINEERS, INC.

Drains - Drains should be checked at least every two months for leaks and clogging. A clogged drain can create ponding on the deck, leading to slab deterioration.

Ponding - Ponded water causes rapid deterioration of waterproofing material and then penetrates the concrete. The result is the same as described for cracks. Ponding is caused by faulty drains, bad construction, or poor design. The specifications should call for deck to be tested for ponding by the Contractor before he leaves the project. Architect/Engineer can recommend solutions for problem areas.

Painting - Steel beams may need to be repainted after a period of time. Scratches should be touched up, on a regular basis, as they occur.

Cleaning - Steel beam flanges collect dirt and trash which increases deterioration of the paint. Cleaning should include a regular sweeping of the concrete deck (preferably once a month) and a wash down twice a year. [6] As a minimum, decks in which deicing salt has been used should be washed down yearly.

Inspection - Garages should be inspected every year. Regular inspection for the above items can detect problems before they become too serious or more costly to correct.

H. COST ESTIMATE

Construction Estimate: The construction quantities tabulated below are based on the area of 1/4 of a typical floor of the garage shown in Item D of this Chapter. These quantities could be used for comparative cost of structural construction and waterproofing. Other items such as plumbing, lighting, striping, stairs, foundations, etc., would be similar in cost for all six systems and, therefore, are not included herein. General conditions, overhead, and profit have also been excluded. For sealer quantities listed below, refer to the cost estimate for the “Topped Precast Concrete” system (Chapter 3) for assumptions.

DESCRIPTION	QUANTITY	UNIT
SLAB FORMWORK	13,824	S.F.
W30X148 BEAMS	36.2	TONS
W30X116 GIRDER	2.1	TONS
W14X90 COLUMNS	5.7	TONS
CONCRETE	313	C.Y.
REINFORCING	10	TONS
POST-TENSIONING	13,000	LB.
ARCHITECTURAL P/C PANELS	256	L.F.
CABLE RAILS	1,600	LB.
SEALERS (AVERAGE)	14,500	S.F.
SEALANT	51	L.F.
(AT PERIMETER OF TOP LEVEL ONLY - AVERAGE PER FLOOR)		
AREA ESTIMATED.		14,500 S.F.

Maintenance Estimate: Maintenance quantities tabulated below are based on the area of 1/4 of a typical floor of the garage shown in Item D of this Chapter. These quantities could be used for comparative cost of maintenance items that relate to this particular system. Other items such as sweeping, wash downs, drain cleaning, restriping, etc., would be similar in cost for all six systems and, therefore, are not included herein.

DESCRIPTION	QUANTITY	UNIT
REPLACE SEALERS (AVERAGE)	14,500	S.F.
REPLACE SEALANT	51	L.F.
(AT PERIMETER OF TOP LEVEL ONLY - AVERAGE PER FLOOR)		
PAINTING	14,500	S.F.
AREA ESTIMATED.		14,500 S.F.



Undesirable Systems for 9
Clear Span Open Garages

CHAPTER 9

UNDESIRABLE SYSTEMS FOR CLEAR SPAN OPEN GARAGES

There are three structural systems which have been used for open parking garages in the past, but which we feel are unsuitable. They are not examined in detail in this report but are simply identified in this Chapter, with reasons why they should be avoided.

STEEL FRAME WITH METAL DECK

A cast-in-place concrete slab on composite metal deck, supported by steel beams, is an undesirable system for open garages, although it is suitable and commonly used for parking levels of an enclosed building. The problem in an exposed environment is corrosion of the metal deck. Since the concrete deck is not post-tensioned, thermal and shrinkage cracks inevitably occur. Water enters cracks and is trapped between the concrete and steel deck. Moreover, the deck is fully exposed to moisture on the underside. The deck eventually corrodes and reduces the flexural strength of the slab. In harsh cold climates, where calcium chloride or other salts are used, this system is not recommended by deck manufacturers for open parking garages. [2]

This system could possibly perform satisfactorily in warmer climates if there are enough safeguards, such as using an 18 gauge deck with extra heavy (G90) galvanizing, and a waterproofing membrane with wearing surface wherever the slab is exposed to rain. Even so, frequent inspections and repainting would be necessary.

STEEL JOISTS WITH METAL DECK

This system consists of a thin concrete slab on metal deck, over steel bar joists spaced at 2 to 3 feet on center, supported on steel beams and steel columns.

Steel bar joists do not have a great amount of stiffness, which results in a loud, bouncy floor as traffic moves across it. They have numerous surfaces exposed to the weather and are subject to corrosion. They are difficult to repaint. The system also requires metal deck, which eliminates its practicality for open parking structures due to the problems with deck corrosion identified above in "Steel Frame with Metal Deck." A fire rating requirement would also preclude the use of exposed joists.

CONVENTIONALLY REINFORCED CONCRETE FRAME

This non-post-tensioned concrete system is usually constructed either as a one-way beam and slab, one or two-way joist, flat plate, or flat slab with or without drop panels. Span limitations of conventionally reinforced concrete require closer column spacing and more columns. Without post-tensioning, beams of reasonable depth cannot span the 55 to 62 feet that is desired for open parking garages. The close column spacing reduces parking spaces, causes traffic movement problems, and hinders ramping, lighting, and security. Without post-tensioning, random tension cracks occur in concrete slabs and beams due to loading, shrinkage, and thermal stresses, leading to water infiltration, corrosion and deterioration.

This system is acceptable and widely used in garages which are enclosed by exterior walls, such as lower levels and basements of buildings. In these cases, close column spacing is more acceptable since the non-garage part of the building will usually have relatively closely spaced columns anyway. In addition, the concrete will not be susceptible to severe temperature and moisture fluctuations, since it is enclosed. Cast-in-place concrete with conventional reinforcing is easy to build and is common construction, creating competitive bidding. However, it should be avoided for open parking garages.



Special Design Considerations 10

CHAPTER 10

SPECIAL DESIGN CONSIDERATIONS

STRUCTURAL DESIGN CRITERIA

- A. Design live load is typically the greater of 40 pounds per square foot or a 3,000 pound concentrated load placed at any location in the driving and parking areas.
- B. Live load on floor slabs should not be reduced for design of members supporting one floor only.
- C. Live loads on elements supporting multiple floors, such as piers and columns, may be reduced by 20% per International Building Code. Note that some older codes do not allow reductions.
- D. Snow loads must be added to live loads where vehicles park on the roof. Each project should be evaluated as to its susceptibility to snow loads. Designing for snow and live loads on the roof may produce excessive camber and increased member shortening in prestressed and post-tensioned concrete which need to be accounted for in design.
- E. Wind loads should be applied to the gross area of the exterior elevation (without reduction due to openings).
- F. ACI or PCI crack control design must be applied to all members. All members in an open parking structure should be classified as “exposed to weather” for purposes of applying the crack control formulas. Unsightly cracks alarm owners and reduce the life of the structure due to weathering.
- G. Seismic and other loads should be applied where applicable.

These loads are recommended as minimum design criteria. The applicable building code must be investigated and complied with for each project.

SHEAR WALLS

Solid concrete walls are often used for lateral frame stability. Stiffness of these walls creates restraints which can cause cracks in the floor as shrinkage and creep take place in the slab and frame. Ideally, these walls should be located near the center of the structure to minimize restraints. On post-tensioned garages a strip of concrete should be left out between the slab and wall if the wall isn't located near the center. This strip can be filled in later, after most shrinkage and creep has occurred in the post-tensioned framing.

RAMPS

The most economical type of ramp is the ramped parking bay, where an entire 60 foot wide bay is sloped. When the ramp slope is established as 6% or less, parking can occur on both sides of the driveway. Ramps up to 12% maximum are acceptable but parking is not recommended on these steeper slopes. Steeper slopes, up to 16%, may be permitted if transition slopes are provided at the top and bottom of the ramp.

STAIRS

Stairs can be made of precast concrete, cast-in-place concrete, or steel. When stairs are enclosed and supported by solid concrete walls, the walls can provide fireproofing and lateral wind resistance. Applicable building codes should be investigated to determine access/exit requirements and whether or not stairs require an enclosure and door. Normally, stairs in open parking garages need not be enclosed unless adjacent to other buildings. Enclosures should be avoided when possible for security reasons.

VENTILATION

One of the economic advantages of open parking structures is natural ventilation. No mechanical ventilation equipment is required. Local building codes govern the amount of open area necessary to dissipate automobile exhaust. Normally they require about 20% of the perimeter surface area to be open.

FIREPROOFING

Typically, open parking structures don't require a specific fire rating if less than 75 feet tall. Some codes require a 1 hour fire rated wall without openings, on the side of a garage located within 20 feet of a building or an interior property line. Any enclosed occupancy within the garage may require special fireproofing. Each project should be investigated, prior to design, to determine whether a fire rating is required by applicable building codes or by the insurance carrier. Where a fire rated structure is required, details recommended in this study might have to be altered. Specifically, check concrete cover, minimum material properties, topping thickness, joint fillers in untopped systems, protection of structural steel, and sprinkler requirements.

CLEARANCE

A typical garage has a 10'-0" floor to floor height with a 2'-10" maximum structural depth and a 7'-2" clearance. While 7'-0" minimum clearance is required by code, the additional 2" allows for construction tolerances, deflections and slopes and accommodates all automobiles and most trucks and vans. (see "ADA & Accessibility" for more requirements) Applicable building codes should be reviewed for minimum clearance requirements. Clearance limitation signs should be prominently posted showing height limits at all vehicle entrances. "Headache bars" are advisable to prevent damage to the structure. Clearance violations often occur at high points in the slab on grade, ramp transition slopes, entrances, story setbacks, and high points of cambered members in certain situations. These areas must be carefully checked to avoid violations.

EXITS

Every open parking structure and floor level should have at least two pedestrian exits. Additional exits should be provided so that no part of the structure will be more than 300 feet from an exit. Exits in all open parking structures should be placed as far apart as practical and be located in such a way that if any exit is blocked, another exit is available from every part of the facility. Refer to the applicable building code for exact requirements. [4]

HANDRAILS

Stair wells, shafts and other open exposed spaces (except floors at grade) should be protected by walls or protective handrails at least 3'-6" in height on all sides. [4] Where open railing is used, the spacing of the intermediate rails should limit the maximum opening width to 4".

IMPACT BARRIERS

Railing should be placed wherever an automobile has access to the perimeter of the structure and along any edges where differences in floor elevation is greater than 12". Barrier railings should not be less than 2'-0" in height and are quite often 3'-6" in height, to meet the handrail requirements. They should be designed for minimum horizontal load of 6,000 pounds, applied at a height of 1'-6" above the floor at any point along the rail. If barrier railing and handrails are used, no other barriers such as wheel stops or curbs, are normally necessary. Cable rails should be designed to limit stretch upon impact. Exterior panels can be knocked off during impact if cables are too long between anchorages. Columns, posts, and walls used to anchor cable rails must be designed to withstand the high tension forces imparted by cables during impact, as well as static anchorage forces and other dead and live loads. These forces will be several times higher than the impact load itself.

LIGHTING

Generally, either mercury or high pressure sodium vapor lighting is used. These are rapidly replacing fluorescent lighting. The minimum amount of illumination provided should be 5 footcandles for interior driving aisles and 0.5 footcandles for other areas. These illumination levels are measured at the floor. Every required exit at each floor should have an illuminated exit sign with 5" minimum lettering. [4] The flat ceilings of post-tensioned slabs make lighting more effective than under double tee or joist decks. Electrical conduit (whether exposed or embedded in the concrete) should always be galvanized.

FIRE PROTECTION

The only fire protection required and normally provided in an open parking structure is a fire department dry standpipe. Standpipes should be provided at each stair with one 2 1/2" outlet between 2 and 4 feet above the floor. A fire department connection should be at street level 1 1/2 to 4 feet above grade. The size of the standpipe varies from 4" to 6" depending on the height of the garage.

SECURITY

Openness of clear span parking garages provides a safer environment than enclosed garages with tighter column spacing. Openness is desirable since garages normally don't have security guards or cameras. Stair wells should be open, when possible, and well lit. Other enclosures, interior walls, and dark corners should be avoided. Good lighting and walls made from white cement or painted a light color will increase brightness.

DRAINAGE

All areas of the parking deck must have a positive slope to a drain or scupper. Ponding must be avoided. A minimum floor slope of 1%, or 1/8" per foot along the valley, must be designed into the project and properly implemented during construction. 2% slope or 1/4" per foot is more desirable, particularly in untopped precast concrete systems. Proper drain size and spacing is essential. Drains should be a minimum of 8" in diameter and be set 1" below the surrounding concrete surface to avoid ponding near drains. There should be a continuous trench drain across the bottom of the uppermost ramp to collect all rainwater coming down the ramp. Be sure to consider excess camber of the long precast and post-tensioned members when designing slopes. (see "ADA & Accessibility" for more requirements)

ADA & ACCESSIBILITY

In areas used for accessible parking and accessible routes, there are additional requirements for maximum cross-slope and minimum headroom. For such areas, a minimum headroom of 8'- 2" is required; as with typical floors, this is generally increased to 8'- 4" to allow for construction tolerances, deflections and slopes. The maximum cross-slope for accessible routes is 2%. Therefore, although 2% slope along the valley is preferred, it cannot be used in accessible areas since this slope will result in greater cross-slopes. Accessible parking and routes should be considered early in design as they will have a significant impact on floor to floor heights and floor slopes.

SEALERS

Concrete surface sealers are intended to reduce moisture and salt penetration of the floor surface. Sealers are polyurethanes, silanes, siloxanes, epoxy resins, methylmethacrylate, and boiled linseed oil with mineral spirits. Polyurethanes are most often used, but do not perform well when exposed to direct sunlight, such as on the roof deck. The roof deck should receive either a silane or siloxane sealer, or a waterproofing membrane system. Epoxies are excellent but are expensive. A quality sealer should be applied to all slabs after the concrete has cured and the surface is clean and dry. Curing compounds, if used, must be compatible with the sealer.

WATERPROOFING MEMBRANE

Surface membranes may be used on the roof in lieu of sealers. Membranes are more effective for keeping water out of the concrete, but also more expensive. Membranes are recommended on decks over occupied spaces, such as retail areas. Membrane systems usually incorporate an aggregate wearing surface.

EXPANSION JOINTS

In a recent survey of 39 precast parking, structures, 21 had expansion joints and 18 of the 21 had problems. Because they require extensive maintenance, expansion joints should be avoided when possible. A quality expansion joint must be specified, detailed, built, and properly maintained, otherwise, it can crack in cold weather, lose joint material, fill with gravel and debris, bulge out in hot weather, cause noises under traffic, and create toe stumpers and heel catchers. Expansion joints must be continuous throughout their entire length in the structure. They should be avoided in turning areas in order to prevent localized stresses from tires and should be located at high points in the structure to direct water away from the expansion joint.

OTHER JOINTS AND SEALANTS

Control joints should be tooled into the topping over precast member joints to control cracking. Other joints include construction joints, joints between deck members in untopped garages, and perimeter joints between the slab and precast spandrel beams or walls. In post-tensioned slabs, all joints on the top level should be filled with a high quality polyurethane sealant to prevent leaks and protect reinforcing, post-tensioning, and post-tensioning anchors. Whether or not the joints on the lower levels are sealed is dependent on the system, the climate, and the level of quality desired by the owner. The owner must be aware that the maintenance and periodic replacement of joint sealants is a necessary operating expense.

FUTURE EXPANSION

Many parking garages are designed for future expansion where parking needs are expected to increase. It is sometimes cost effective to design for current needs, but to make an initial investment in larger foundations, conduits, drainage lines, etc., to accommodate future expansion. All of the consultants must work together to accomplish this. The structural engineer must provide larger columns, footings, shear walls, and a means of attaching new columns to the existing columns. The mechanical and electrical engineers must provide larger drain lines, conduits, and space for additional electrical panels. The architect must design elevators that can be expanded vertically, stairs and knockout panels to accommodate more entrances and exits, cashier booths, and ticket machines. [22] The drawings should clearly identify what, if any, future vertical expansion has been provided for.

FINISHES

Generally, parking and drive areas within a garage will get a light broom finish. Large horizontal floors may be troweled. Curbs, islands, walks, and stairs usually receive a light broom finish. Steep entrance/exit ramps need a heavy broom or raked finish, particularly when partially exposed to weather. The direction of the striations should be parallel to the slope for good drainage. A light broom finish is usually best when applying a protective coating. Exposed, formed interior concrete surfaces are usually just pointed and patched. A rubbed finish may be desired on high quality work, but it is expensive.

PAINT

Interior surfaces of cast-in-place and precast concrete are usually not painted due to initial and future repainting cost. Coloring of concrete can best be achieved by specifying particular cement types or adding pigment to the concrete mix. Structural steel is normally shop and field painted with a system which provides a paint life of up to 10 years. A three coat system can provide longer paint life.



Quality Control 11

CHAPTER 11

QUALITY CONTROL

Adequate quality control measures are essential to constructing a durable, long lasting, low maintenance garage. The following are some key quality control points which pertain to all garage structural systems:

CONCRETE AGGREGATE - When exposed to weather and traffic over time, concrete with hardrock aggregate has proven to be more durable than concrete with lightweight aggregates. Therefore, normal weight aggregate should be used whenever possible, unless fire rating or span limitations dictate lightweight. Lightweight aggregate double tees are acceptable under a hardrock topping and will often produce a savings on 55 to 62 foot spans. It is recommended to use hardrock concrete in double tees on untopped systems since the double tee itself is the wearing surface. In addition, aggregates must not be contaminated with chlorides.

CONCRETE MIX - Maintaining a maximum water/cement ratio of 0.45 in the concrete mix greatly enhances the durability of the concrete by decreasing its permeability. Even if a superplasticizer is not added to offset the resulting low slump, maintaining this ratio is well worth dealing with low slump concrete. Cement and mixing water must be free of chlorides.

ADMIXTURES

Chlorides Admixtures containing chlorides or other salts must not be used. This is typically found in cold weather accelerators, which contain calcium chloride, or in water reducing agents.

Calcium Nitrite This is a corrosive-inhibiting admixture developed specifically to address the problem of corrosion of steel by chlorides. This admixture may be cost effective in extending the life of parking decks that are exposed to chlorides. [21]

Air Entrainment As noted in this report, air entrainment is of vital importance for concrete exposed to the elements. Air entrainment protects the top surface from scaling and flaking due to repeated freeze/thaw cycles. It also reduces the amount of mix water which lowers the water/cement ratio, bleedwater, and shrinkage, and it improves workability.

Superplasticizer The low slump concrete produced by limiting the water/cement ratio to 0.45 can be made more workable and fluid by adding a superplasticizer. This will result in a better finished product and is well worth the expense.

Microsilica (or “silica fume”) When used in conjunction with a superplasticizer it produces a denser, higher strength concrete with greatly reduced permeability. It is not widely used at this time, but is gaining acceptance and should be considered.

CONCRETE PLACEMENT - Quality control must be maintained at the jobsite. Uncontrolled addition of mixing water will reduce concrete strength and durability. Air content and slump should be checked at the end of pump lines.

FINISHING PROCEDURES

Troweling Do not begin finishing until bleedwater has evaporated. Finishing too soon will work the bleedwater back into the top layer of concrete, giving it a high water/cement ratio. This reduces the strength and soundness of this layer for traffic durability. It also causes cracking and crazing as the concrete cures. Overfinishing or excessive finishing can cause loss of entrained air in the top layer reducing the freeze/thaw resistance of the concrete. Sprinkling the surface with water to aid in finishing can cause scaling.

Sloped Surfaces Use a medium broom or float swirl finish on all surfaces with a slope of less than 10%. Avoid a hand troweled finish. Ramps with slopes greater than 10% shall receive a raked finish, parallel to the ramp slope.

Joint Tooling Joints in the cast-in-place concrete topping over precast members, as described earlier, must be tooled and not sawcut. A Goldblatt Groover (Model No. 06314M7) is recommended to provide the proper width and depth for sealant application. Sawcutting is not allowed for the following reasons:

1. Tooling must be performed while the concrete is still plastic. If sawcutting is allowed, cracks may develop before joints are cut.
2. If sawing is done when the concrete is too green, the edges will ravel.
3. The square edges of a sawn joint can break off under traffic. Tooled joints are rounded and therefore more durable.
4. It is easier to seal a tooled joint due to its openness, visibility, ease of cleaning, and size.
5. Tooled joints are easier to locate than sawn joints because joint markers can be set and removed in the wet concrete.
6. Rebar and electrical conduit can be cut accidentally during sawing.
7. When mesh or rebar is cut the joint acts more like an expansion joint than a control joint and causes the sealant to fail.

CURING - The equivalent of seven days of water curing of the concrete with wet burlap is a critical quality control requirement. A continuously sprayed water fog is an ideal curing method. If a curing compound is used, the compound must be compatible with the sealer specified for use.

POST-TENSIONING TENDONS - To avoid problems with tendon corrosion and failure, provide encapsulated tendons in tight, well greased sheathing with no tears, proper placement, and full protection of the end anchorage. [46]

REINFORCING COVER - Proper concrete cover over reinforcing can help to prevent corrosion, spalling, concrete staining, and reinforcing bar shadows. The minimum concrete cover requirements of ACI 318, Section 7.7 must be maintained. In open parking garages a minimum cover of 1 1/2" on all reinforcing in the top of a stressed slab and 2" or 2 1/2 bar diameters in nonstressed slabs will considerably improve the corrosion resistance of the structure. Electrical conduit embedded in concrete should always be galvanized and comply with these cover requirements.

SEALING - The specified sealer and joint waterproofing must be installed in strict accordance with the specifications and manufacturer's recommendations, and a warranty provided.

BEARING PADS - Neoprene bearing pads must be used at all bearing conditions in a precast garage. Bearing pads work to evenly distribute the load over an uneven surface and to allow movement to take place at the joints, thus preventing restraint forces. In a recent survey of existing parking structures, it was observed that when bearing pads were used, the concrete at member ends was in good shape. This was true even if the pad exhibited distress. Conversely, when bearing pads were not used, member ends were consistently cracked or spalled. [6] When pads fail, it is either due to being too small, improperly placed, or made of inferior material.

INSPECTION - Inspection services are of particular importance for open parking structures. Contractors may be inexperienced with many of the special materials often used to build parking garages. While the International Building Code provides for minimum independent testing and inspections, it is in the owner's and contractor's best interest to insist on careful and frequent additional inspections by the testing laboratory, both at the batching plant and at the jobsite. Specifications should cover inspection services thoroughly. One particularly important item is precast bearings. All bearing pads must be properly located before topping is cast or members welded together. Correcting deficient bearings after pouring the topping is nearly impossible and usually requires unsightly steel brackets.

HARSH COLD CLIMATES - When salt is used for deicing, special requirements such as epoxy coated reinforcing steel, thicker slabs, and more admixtures in the concrete should be specified to prevent corrosion of the reinforcing steel. These requirements should also become important aspects of the field quality control program, such as making sure epoxy coatings are touched up and checking for proper cover before concrete is poured.

COSTAL AREAS - Open parking structures in coastal areas are subject to airborne salt which can accelerate corrosion. Special precautions, similar to those described above for harsh cold climates, must be taken for garages in these areas.



Conclusion 12

CHAPTER 12 CONCLUSIONS

With adequate attention to details, specifications, locality, and maintenance, any one of the six structural systems reviewed in this report can successfully be used for an open parking structure. However, some are better suited to certain areas of the country than others.

Based on quality and durability considerations, we are favorably impressed with both the untopped precast concrete system and the cast-in-place systems with post-tensioning in two directions. Each project should be analyzed for the specific conditions that influence the cost, construction time, and constructibility for its location.

All garage structural systems can be improved for longer, problem-free existence by means of the following:

High Quality design.

Refined specifications.

Closer attention to details by the Contractor.

Vigilant inspection during construction by the Special Inspector and by the Engineer or Testing Laboratory.

Better understanding of, and attention to, maintenance needs by the Owner.

Understanding the importance of these should lead to implementation of the recommendations contained in this book.

On any new garage project, comparative cost estimates of the structural systems known to be competitive in that particular geographic area should be made to determine the most cost effective system on a life-cycle basis for that specific project. Then, the owner and design team should work together to achieve the desired level of quality and durability. This report can be used as a starting point in that process.



References 13

**CHAPTER 13
REFERENCES**

1. Walker, H. Carl, "Durability of Parking Structure Floors," Parking Structures, ACI Compilation No. 3.
2. "Guidelines for Q-Lock Slabs Used For Parking Garages," Q-Lock Floor Standard, 1033-B, Page No. Q3-3-3.
3. May, Howard R., "Parking Garage Maintenance Manual."
4. "Building Code Provisions for Open Parking Structures," National Parking Association Parking Consultants Council, July 1980 (Revised).
5. Robison, Rita, "The Parking Problem," Civil Engineering/ASCE, March 1986.
6. The Consulting Engineers Group, Inc., "Survey of Precast Prestressed Concrete Parking Structures."
7. Monroe, Dave, "Principles of Watertight Concrete Construction for Parking Structures," ACI Compilation.
8. Shah, Pradeep, "Designing Parking Structures to Minimize Maintenance," ACI Compilation.
9. "State-of-the-art Report on Parking Structure," ACI Committee 362, ACI Compilation.
10. Peterson, Carl A., "Survey of Parking Structures Deterioration and Distress," ACI Compliation.
11. Hunnicutt, James M., "A Consultant Looks at Structural Steel and Parking Decks," Modern Steel Construction.
12. Erickson, Donald, A., "Problems Encountered with Post-tensioned Unbonded Tendons," The Building Official and Code Administrator, July/August, 1985.
13. "Specifications for Unbonded Single Strand Tendons," Post-tensioning Institute.
14. "Parking Structures," Precast Concrete Institute.
15. Tucker, Richard L., "Parking Structures - Construction Problems and Solutions," ACI Compilation.
16. Hunnicutt, James, M., "Parking Deck Deterioration - The Reasons Why," Concrete Construction, September 1976.
17. Knoblock, George C., Jr., "Sealing Concrete Pavement Joints for Zero Maintenance," Concrete Construction, August 1977.
18. Walker, Carl H., "Designing Durable Maintenance-free Prestressed Concrete Parking Structures," Concrete Construction, July 1977.
19. McCall, Calvin W., "Parking Deck Parades Precast," Concrete International, November 1984.
20. "Site-Cast Concrete Parking Structures," CRSI and PTI Publication.
21. "To Prevent Corrosion, Stop it Dead in its Tracks," Concrete Construction, September 1979.
22. Walker, Carl H., "Planning Parking Structures for Future Expansion," National Parking Association.
23. "Public Parking Structures Design and Construction," Seymore Gage Associates.

24. "Design of Concrete Parking Structures - Problems and Solutions," ACI seminar course manual SCM-12 (86).
25. "Cathodic Protection Prevents Corrosion Damage on Reinforced Concrete Parking Structures," Harco Corporation, Paper No. HC-50.
26. "Structural Deterioration and Rehabilitation," National Parking Association Compilation, 1985.
27. "Building Code Requirements for Reinforced Concrete (ACI 318-89)" American Concrete Institute, Detroit, 1989.
28. "PCI Design Handbook, Precast and Prestressed Concrete," Third Edition, Prestressed Concrete Institute, Chicago, 1985.
29. "Designing for Creep and Shrinkage in Concrete Structures," SP-76, American Concrete Institute, Detroit, 1984.
30. "Troubleshooting Concrete Problems - and how to prevent them in the future," ACI Seminar Course Manual SCM-17 (87).
31. Gibson, Frances, W., "Corrosion, Concrete, and Chlorides," SP-102, American Concrete Institute, Detroit, 1987.
32. Whiting, David, and WaLitt, Arthur, "Permeability of Concrete," SP-108, American concrete Institute, Detroit, 1988.
33. "Parking Structures," ACI Compilation No. 3, American Concrete Institute, 1980.
34. Wiss, Janney, Elstner Associates, Inc., "Corrosion Protection Tests on Reinforced Concrete," September 24, 1986.
35. "Recommended Practice for Design, Manufacture, Erection, and Maintenance of Precast, Prestressed, Parking Structures," PCI Committee on Parking Structures, 1987.
36. Wiss, Janney, Elstner Associates, Inc., "Bellevue Square Parking Garage Sealer Test," Bellevue, Washington, November 18, 1987.
37. Schupack, Morris & Suarez, Mario G., "Some Recent Corrosion Embrittlement Failures of Prestressing Systems in the United States," PCI Journal, March - April 1982.
38. "Tentative Recommendations for the Corrosion Protection of Unbonded Tendons," PCI Journal, January - February 1983.
39. "Guide For Design and Construction of Concrete Parking Lots," ACI Committee 330, January 1988.
40. "Concrete Sealers for Protection of Bridge Structures," National Cooperative Highway Research Program Report 244.
41. Wiss, Janney, Elstner and Associates, Inc., "Concrete Sealers for Protection of Bridge Structures," Highway Research Program Report 244, 1981.
42. "Parking Structures: Recommended Practice for Design and Construction," Prestressed Concrete Institute, Chicago, 1988.
43. "Prediction of Creep, Shrinkage, and Temperature Effects in Concrete Structures," ACI Committee 209, 1982.
44. "Steel Offers Cost Benefits," ENR Special Advertising Section, August 19, 1991.
45. "New Technology Overcomes Maintenance Fears," Modern Steel Construction, Sept. - Oct. 1990.
46. Schupack, Morris, "Corrosion Protection for Unbonded Tendons," Concrete International, February 1991.

The Art of
Structural
Engineering



1420 W Mockingbird Lane, Suite 100 Dallas, Texas 75247 214.358.0174
8140 N Mopac Expressway, Building One, Suite 120 Austin, TX 78759 512.469.9490
311 Sixth Street San Antonio, TX 78215 210.858.2880

datumengineers.com